

Spare Parts Catalogue

Standard Electric Wire Rope Hoists MT and MTL Series

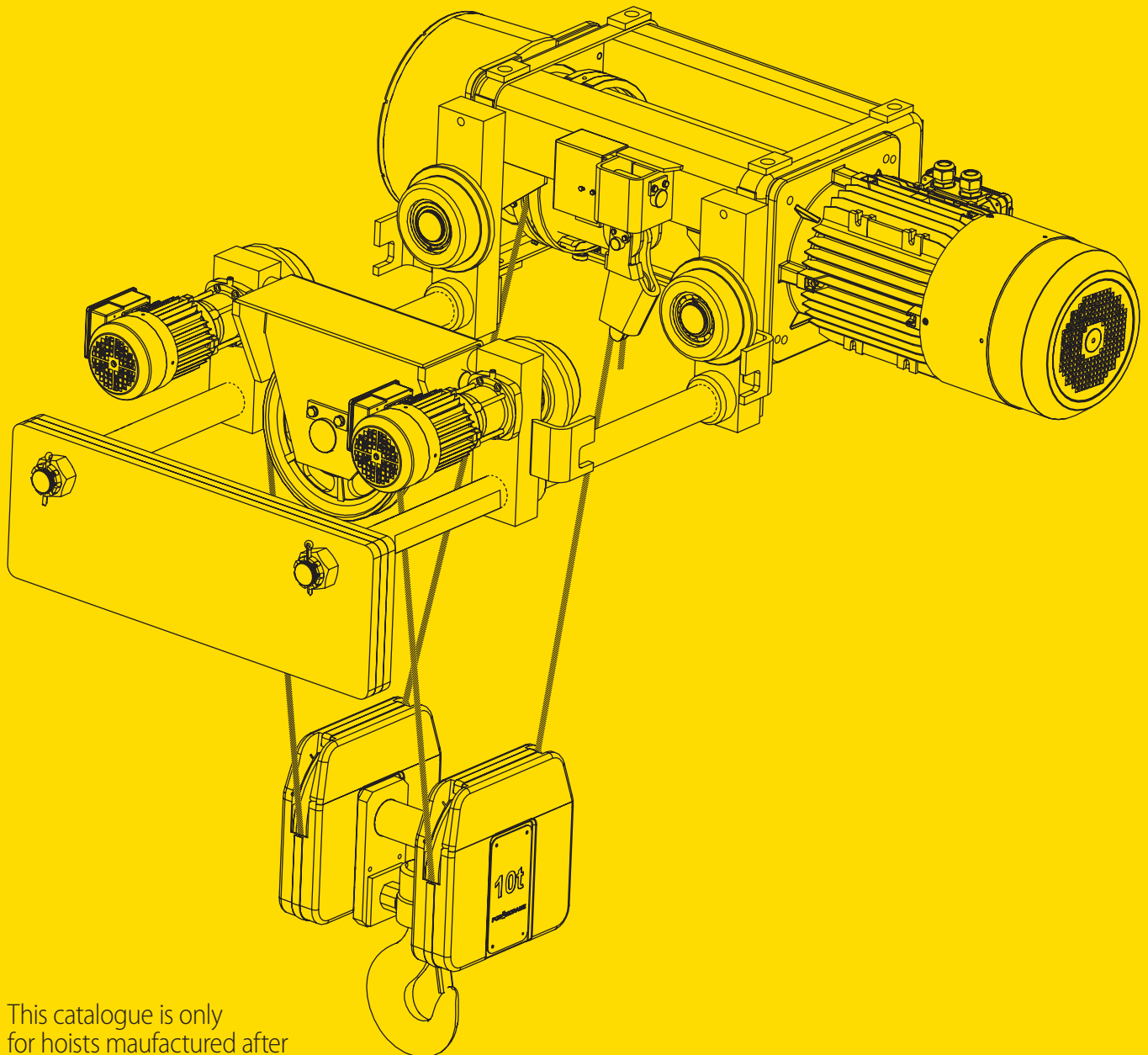

This catalogue is only
for hoists manufactured after
1st January 2007

1	Instruction for Using the Catalogue
2	Group 1 – Lifting Reducer
6	Group 2 – Drum, Rope, End-limit Switch
10	Group 3 – Clutch and Shaft Set
11	Group 4 – Rope Guide
12	Group 5 – Fixing the Rope to the Body
14	Group 6 – Load Limiter
16	Group 7 – Traverse with Block Roller (Set) – Reeving 4/1
18	Group 8 – Block Hook
22	Group 9 – Suspension and Travel Mechanism – Low Headroom
31	Group 10 – Electric Motor
43	Group 11 – Travel Mechanism – Normal Headroom
52	Group 12 – Electrical Equipment
55	Designations of Hoist Type MT and MTL
56	Group 13 – Fast Wearing Parts
56	Group 14 – Accessories
57	Request / Appendix N°1

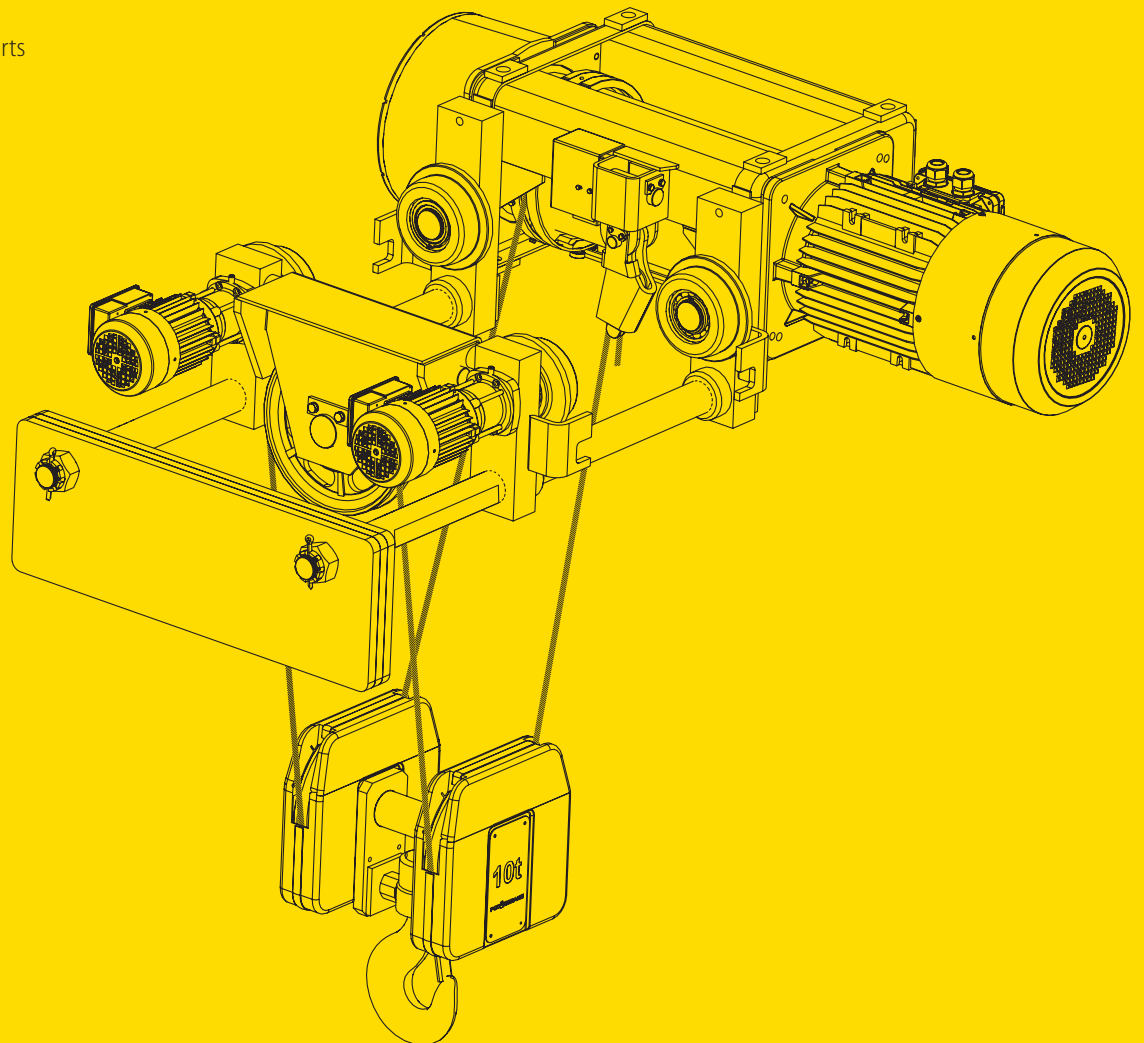

Instruction for Using the Catalogue

When using the catalog, identify the spare part which you need of the appropriate figure and its catalog from the first column of the table.

The catalog comprises parts which are manufactured wire rope electric hoist type MTM and MTL.

The position of the figures and the catalog number depend on the function of the part and sequence assembly. Established sequence will help you in the preparation of the request for spare parts and will serve you as a guide for repairing the hoist.

For your convenience the lifting heights are marked with H0, H1, H2 и H3.

Reeving	H0	H1	H2	H3
	Lifting height (m)			
2/1	10	14	20	26
4/1	*	7	10	13

* H0 is unavailable for 4/1 reeving.

To avoid mistakes, every spare part must contain the following information:

Type, serial number and year of manufacture of the wire rope electric hoist.



Name and catalog number of the corresponding spare part.



Quantity of the necessary spare parts.

Standard fasteners (bolts, screws, nuts, springs, washers and etc.) as shown on page 53–54, table 12.2. They are referred to help you when you repair the wire rope electric hoist, but they are not available for sale. Podem is not responsible for their quality.

Podem reserves the right to change the "Spare Parts Catalog" without notice.

Table 1.1

MT Series		Lifting speed							
		V1		V2		V1		V2	
Fig.	Pos.	Name	Qty	Catalog №					
				MT305–308		MT312–316		MT525	
1 a	1–39	Reducer	1	808987	809321	809432	809433	809880	809881
1 a		Shaft (Input) (Pos. 2, 4, 5, 6, 7, 8, 9, 12, 13)	1	808988	809322	808192	808499	809235	809412
1 a	7	Ring*		207473	207473	208714	208714	809239	809239
1 a	5	Bearing*		210723	210723	206047	206047	205981	205981
1 a	13	Sun gear I		808993	809324	808196	808501	–	809415
1 a	2	Cover		808990	808990	186184	186184	809244	809244
1 a	6	Ring*		811036	811036	208727	208727	208727	208727
1 a	8	Cover for reducer		806828	806828	805616	805616	805616	805616
1 a	4	Ring	1	809892	809892	804793	804793	804793	804793
1 a	12	Bush	1	808992	808992	180099	180099	809243	809243
1 a	9	Shaft	1	808994	808994	162212	162212	–	816308
1 a		Shaft gear	1	–	–	–	–	816564	–
1 a	11	Bush compensatory	1	808995	808995	162107	162107	809241	809241
1 a		Gear I set (Pos. 10, 14, 15, 16, 17, 18, 19, 20)	1	809003	809323	808193	808500	809236	809413
1 a	17	Planetary gear I		809004	809325	808195	808502	809245	809416
1 a	16	Axle I		162709	162709	162096	162096	162157	162157
1 a	20	Ring*		207473	207473	208716	208716	809249	809249
1 a	10	Sun gear II	1	809006	809006	503059	503059	809247	809247
1 a	18	Bearing*		504900	504900	504901	504901	504902	504902
1 a	19	Ring*		809007	809007	208727	208727	809248	809248
1 a	14	Ring*		809008	809008	208719	208719	208482	208482
1 a	15	Planet carrier I		809005	809326	503065	807527	809246	809417
1 a		Gear II set (Pos. 12, 21, 22, 23, 24, 25, 26, 30, 31,32)	1	809009	809009	808202	808202	809237	809237
1 a	22	Planetary gear I	3	809010	809010	808197	808197	809250	809250
1 a	21	Planet carrier II		809013	809013	807632	807632	809251	809251
1 a	26	Axle II		809012	809012	162222	162222	162564	162564
1 a	24	Ring*		207473	207473	208727	208727	809248	809248
1 a	12	Bush		162038	162038	162817	162817	162561	162561
1 a	23	Bearing*		801446	801446	205981	205981	801424	801424
1 a	25	Ring*		809007	809007	208716	208716	809249	809249
1 a	31	Bearing*		206016	206016	804705	804705	629105	629105
1 a	32	Bearing*		841562	841562	206021	206021	205993	205993
1 a	30	Bearing*		205946	205946	251241	251241	205981	205981
1 a		Geared bush (set) (Pos. 27, 28, 29, 30, 32)	1			162471	162471		
1 a	27	Geared bush		807168	807168	162224	162224	809252	809252
1 a	28	Bush		162935	162935	162225	162225	162567	162567
1 a		Ring*		809249	809249	207472	207472	208713	208713
1 a	1	Reducer body		809015	809015	809135	809135	809878	809878
1 a	36	Stop sector		809316	809316	160092	160092	160152	160152
1 a	35	Safety pad		809317	809317	160094	160094	160154	160154
1 a	34	Bolt*		805232	805232	805232	805232	805149	805149
1 a	38	Drain plug		581527	581527	581527	581527	581527	581527
1 a	29	Ring*		207473	207473	208714	208714	809239	809239
1 a	39	Screw*		825382	825382	207936	207936	207936	207936
1 a		Spring washer*		805599	805599	805599	805599	805599	805599
1 a	37	Bleed valve		505499	505499	505499	505499	505499	505499
	40	Gasket*		208046	208046	209102	209102	208054	208054
		Gasket*		208043	208043	208049	208049	208055	208055

– When you order reducer or spare parts for reducer please indicate the manufacture year of the hoist.

– * For DIN or BDS designations please see page 53–54, table 12.2

Lifting Reducer MT

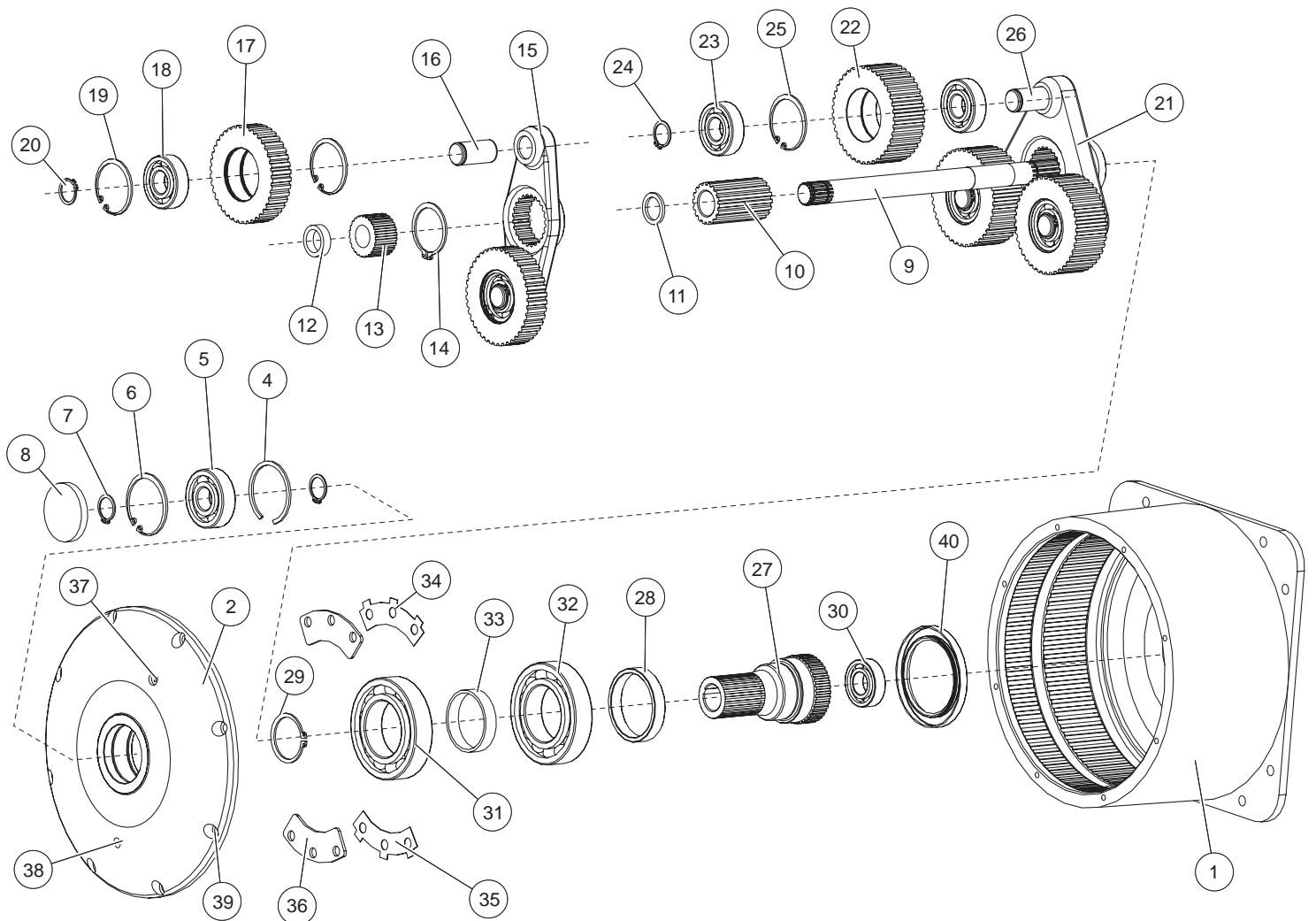

Fig. 1 a

Table 1.2

Grease			
	Lifting speed (m/min)	Qty (kg)	Catalog №
MT305-308	V1-V2	0.8	809211
MT/MTL312-316	V1-V2	1	809211
MT/MTL525	V1-V2	1.2	809211

– * Podem recommend grease Total Ceran CA

Table 1.3

MTL Series				Lifting speed					
				V1	V2	V1	V2	V1	V2
Fig.	Pos.	Name	Qty	Catalog №					
				MTL312	MTL316		MTL525		
1 b		Gear motor		–		–		–	
1 c	32	El. motor			See table 10.5				
1 b	1-31	Reducer		–	815912	–	815912	–	816020
1 b	1-8	Gear I set	1	–	808500	–	808500	–	809413
1 b	3	Planetary gear		–	808502	–	808502	–	809416
1 b	1	Planet carrier I		–	807527	–	807527	–	809417
1 b	2	Axle I		–	162096	–	162096	–	162157
1 b	7	Sun gear		–	503059	–	503059	–	809247
1 b	5	Ring*		–	208727	–	208727	–	809248
1 b	4	Bearing*		–	504901	–	504901	–	504902
1 b	6	Ring*		–	208716	–	208716	–	809249
1 b	8	Ring*		–	208719	–	208719	–	208482
1 b		Gear II set (Pos. 11,12, 13, 15, 16, 17, 18, 20, 23, 26)	1	–	808202	–	808202	–	809237
1 b	13	Planetary gear		–	808197	–	808197	–	809250
1 b	15	Bearing*		–	205981	–	205981	–	801424
1 b	11	Planet carrier II		–	807632	–	807632	–	809251
1 b	12	Axle II		–	162222	–	162222	–	162564
1 b	26	Bearing*		–	804705	–	804705	–	629105
1 b		Geared bush (set) (Pos. 17, 18, 19, 20, 23)	1	–	162471	–	162471	–	
1 b	17	Geared bush	1	–	162224	–	162224	–	809252
1 b	21	Bush	1	–	162225	–	162225	–	162567
1 b	23	Bearing*	1	–	206021	–	206021	–	205993
1 b	18	Bearing*	1	–	251241	–	251241	–	205981
1 b	19	Ring*	1	–	207472	–	207472	–	208713
1 b	22	Bush	1	–	162817	–	162817	–	162561
1 b	20	Ring*	1	–	208734	–	208734	–	809242
1 b	14	Ring*	3	–	208716	–	208716	–	809248
1 b	16	Ring*	3	–	208727	–	208727	–	809249
1 b	25	Stop sector	2	–	160092	–	160092	–	160152
1 b	28	Bolt*	6	–	805232	–	805232	–	805149
1 b	29	Gasket*	1	–	209102	–	209102	–	208054
1 b	24	Safety pad	2	–	160094	–	160094	–	160154
1 b	9	Sun gear	1	–	808501	–	808501	–	809415
1 b		Ring*		–	207472	–	207472	–	
1 b	10	Ring*	2	–	208714	–	208714	–	
1 b	30	Reducer body		–	815772	–	815772	–	815650
1 b	31	Bleed valve		–	505499	–	505499	–	505499
1 b		Grease			See table 1.2				

– * For DIN or BDS designations please see page 53–54, table 12.2

Lifting Reducer MTL

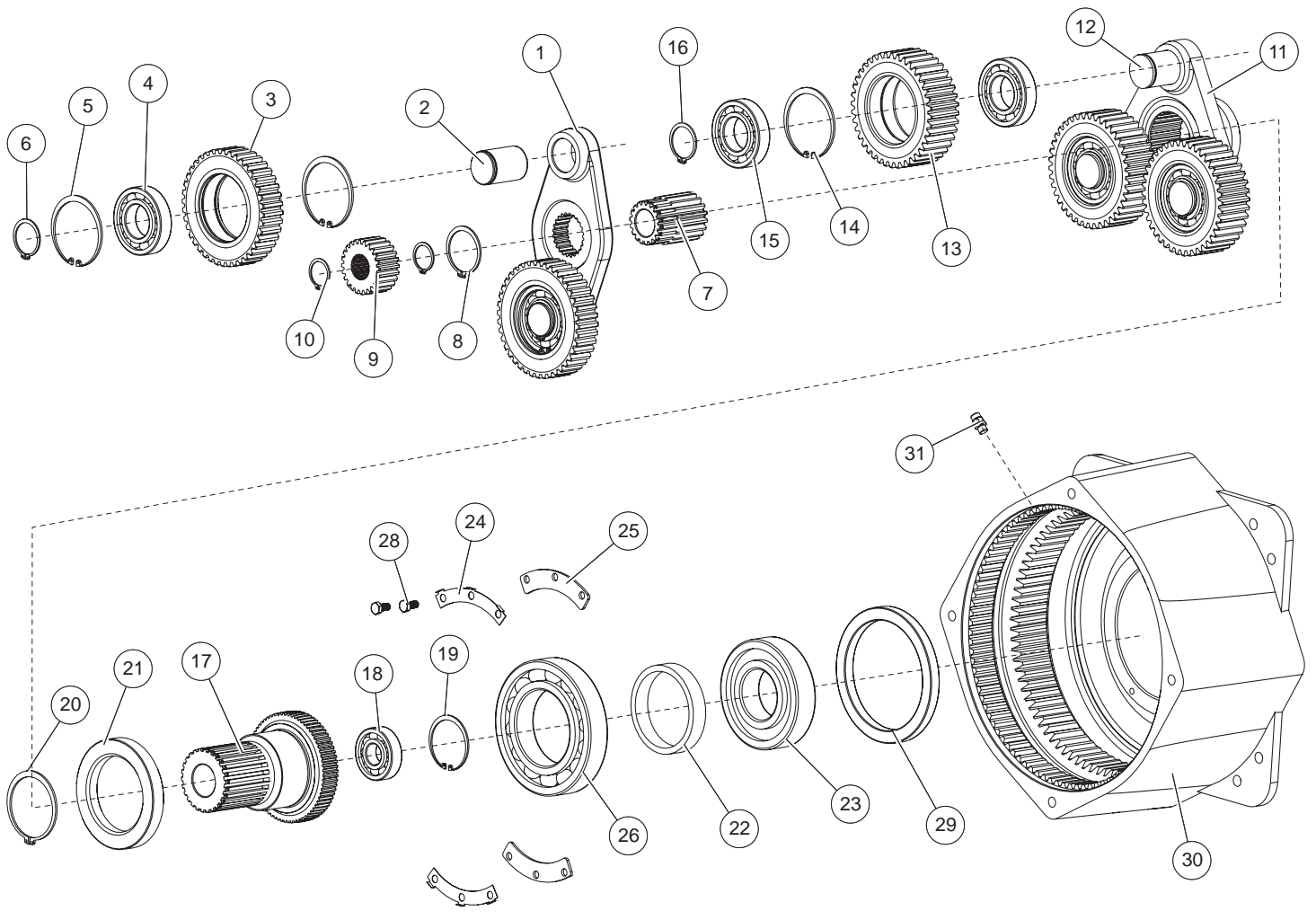

Fig. 1 b

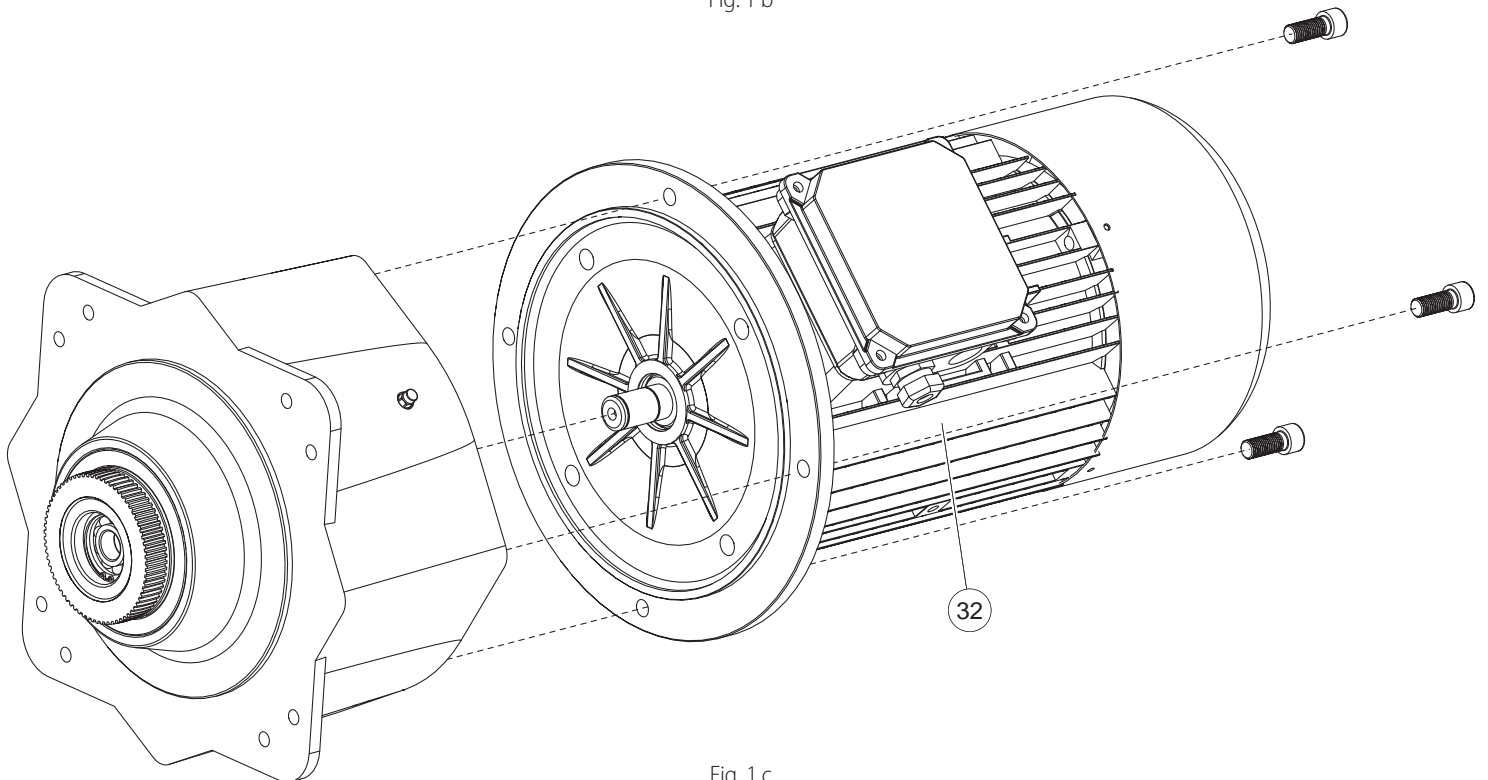

Fig. 1 c

Table 2.1

MT Series						Lifting height			
						H0	H1	H2	H3
Fig.	Pos.	Name	Rope diameter	Reeving	Qty	Catalog N°			
						MT305, MT308			
2	1	Drum set	ø 7 mm	2/1, 4/1	1	808231	503323	503324	807643
2	2	Plate	ø 7 mm	2/1, 4/1	3	811068	811068	811068	811068
2	3	Screw**	ø 7 mm	2/1, 4/1	3	825382	825382	825382	825382
2	18	Rope	ø 7 mm	2/1	–	805865	812685*	812685*	812685*
2	18	Rope	ø 7 mm	4/1	–	–	805865	805865	805865
						MT312, MT316			
2	1	Drum set	ø 10 mm	2/1, 4/1	1	808232	503328	503359	807655
2	2	Plate	ø 10 mm	2/1, 4/1	3	503365	503365	503365	503365
2	3	Screw**	ø 10 mm	2/1, 4/1	3	251386	251386	251386	251386
2	18	Rope	ø 10 mm	2/1	–	805866	806518*	806518*	806518*
2	18	Rope	ø 10 mm	4/1	–	–	805866	805866	805866
						MT525			
2	1	Drum set	ø 12 mm	2/1, 4/1	1	808233	503372	503373	807658
2	2	Plate	ø 12 mm	2/1, 4/1	3	811123	811123	811123	811123
2	3	Screw**	ø 12 mm	2/1, 4/1	3	251386	251386	251386	251386
2	18	Rope	ø 12 mm	2/1	–	805867	806837*	806837*	806837*
2	18	Rope	ø 12 mm	4/1	–	–	805867	805867	805867

– * Non rotating rope. For hoists with lifting height over 13 meters and reeving 4/1.
 – Complete with clamp (See table 5).
 – ** For DIN or BDS designations please see page 53–54, table 12.2

MT

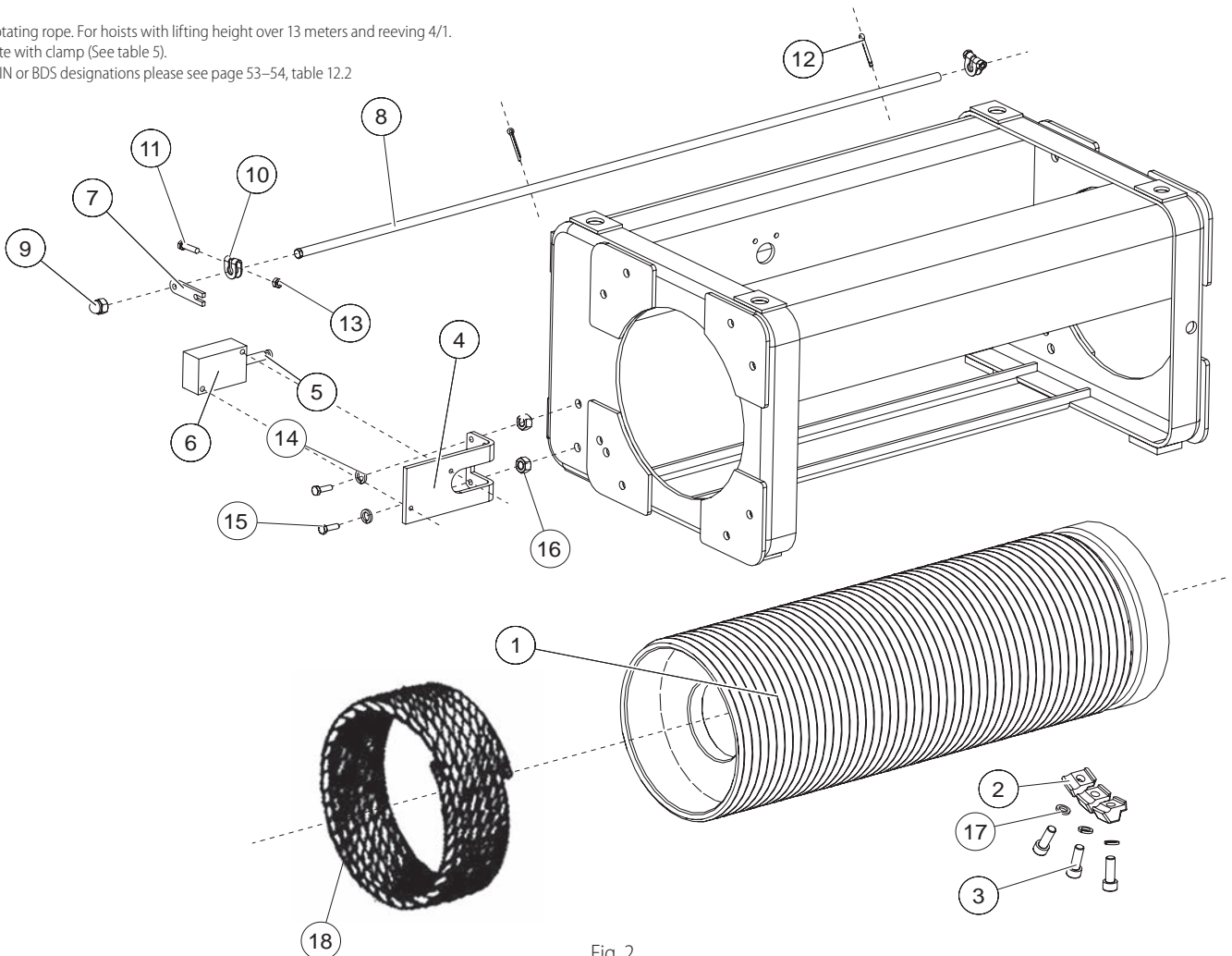

Table 2.2

MT Series						Lifting height			
						H0	H1	H2	H3
Fig.	Pos.	Name	Rope diameter	Reeving	Qty	Catalog N°			
						MT305, MT308			
2	18	Rope length, mm	ø 7 mm	2/1	1	23 800	33 000	45 000	56 300
2	18	Rope length, mm	ø 7 mm	4/1	1	–	33 800	46 000	57 100
						MT312, MT316			
2	18	Rope length, mm	ø 10 mm	2/1	1	24 600	32 600	44 600	57 000
2	18	Rope length, mm	ø 10 mm	4/1	1	–	35 000	46 700	58 000
						MT525			
2	18	Rope length, mm	ø 12 mm	2/1	1	26 000	33 600	45 300	57 600
2	18	Rope length, mm	ø 12 mm	4/1	1	–	35 600	47 600	59 000

Table 2.3

MT Series						Lifting height			
						H0	H1	H2	H3
Fig.	Pos.	Name		Qty	Catalog N°				
						MT305, MT308			
2	–	Bar set* (Pos. 7, 8, 9, 10, 11, 12, 13)		1	1808789	1808703	1808704	1808705	
2	8	Bar		1	808789	808703	808704	808705	
2	10	Ring		2	573283	573283	573283	573283	
2	7	Fork		1	810006	810006	810006	810006	
2	11	Bolt M 6x25**		2	222029	222029	222029	222029	
2	12	Pin DIN 94 2.5x14**		2	211986	211986	211986	211986	
2		Spring washer**		1	805599	805599	805599	805599	
2	9,13	Nut M6**		3	843150	843150	843150	843150	
2	–	Plate set (Pos. 4, 14, 15, 16)		1	810267	810267	810267	810267	
2	4	Plate		1	810075	810075	810075	810075	
2	15	Bolt**		2	805258	805258	805258	805258	
2	14	Spring washer**		2	824894	824894	824894	824894	
2	16	Nut**		2	808143	808143	808143	808143	
2	5	End limit switch (KI G)		1	574478	574478	574478	574478	
2	6	Cover for End limit switch		1	501573	501573	501573	501573	
2	–	Screw**		2	219924	219924	219924	219924	
						MT312, MT316			
2	–	Bar set* (Pos. 7, 8, 9, 10, 11, 12, 13)		1	1808744	1808710	1808710	1808712	
2	8	Bar		1	808744	808710	808711	808712	
2	10	Ring		2	573283	573283	573283	573283	
2	7	Fork		1	809772	809772	809772	809772	
2	11	Bolt M 6x25**		2	222029	222029	222029	222029	
2	12	Pin DIN 94 2.5x14**		2	211986	211986	211986	211986	
2		Spring washer**		1	805599	805599	805599	805599	
2	9,13	Nut M6**		3	843150	843150	843150	843150	
2	–	Plate set (Pos. 4, 14, 15, 16)		1	810267	810267	810267	810267	

Table 2.3

MT Series						Lifting height			
						H0	H1	H2	H3
Fig.	Pos.	Name		Qty		Catalog N°			
						MT312, MT316			
2	4	Plate		1		810075	810075	810075	810075
2	15	Bolt**		2		805258	805258	805258	805258
2	14	Spring washer**		2		824894	824894	824894	824894
2	16	Nut**		2		808143	808143	808143	808143
2	5	End limit switch (KI G)		1		574478	574478	574478	574478
2	6	Cover for End limit switch		1		501573	501573	501573	501573
2	–	Screw**		2		219924	219924	219924	219924
						MT525			
2	–	Bar set* (Pos. 7, 8, 9, 10, 11, 12, 13)		1		1808799	1808694	1808695	1808696
2	8	Bar		1		808799	808694	808695	808696
2	10	Ring		2		573283	573283	573283	573283
2	7	Fork		1		808699	808699	808699	808699
2	11	Bolt M 6x25**		2		222029	222029	222029	222029
2	12	Pin DIN 94 2.5x14**		2		211986	211986	211986	211986
2		Spring washer**		1		805599	805599	805599	805599
2	9,13	Nut M6**		3		843150	843150	843150	843150
2	–	Plate set (Pos. 4, 14, 15, 16)		1		810267	810267	810267	810267
2	4	Plate		1		810075	810075	810075	810075
2	15	Bolt**		2		805258	805258	805258	805258
2	14	Spring washer**		2		824894	824894	824894	824894
2	16	Nut**		2		808143	808143	808143	808143
2	5	End limit switch (KI G)		1		574478	574478	574478	574478
2	6	Cover for End limit switch		1		501573	501573	501573	501573
2	–	Screw**		2		219924	219924	219924	219924

– * For orders – only bar set.

– ** For DIN or BDS designations please see page 53–54, table 12.2

Table 2.4

MTL Series						Lifting height			
						H32	H40	H48	H56
Fig.	Pos.	Name	Rope diameter	Reeving	Qty	Catalog N°			
						MTL312, MTL316			
2	1	Drum set	ø 10 mm	2/1	1	812792	815265	–	815148
2	2	Plate	ø 10 mm	2/1	3	503365	503365	–	503365
2	3	Screw*	ø 10 mm	2/1	3	251386	251386	–	251386
2	18	Rope	ø 10 mm	2/1	–	806518	806518	–	806518
						MTL525			
2	1	Drum set	ø 12 mm	2/1	1	815489	815499	815500	815501
2	2	Plate	ø 12 mm	2/1	3	811123	811123	811123	811123
2	3	Screw*	ø 12 mm	2/1	3	251386	251386	251386	251386
2	18	Rope	ø 12 mm	2/1	–	806837	806837	806837	806837

– * For DIN or BDS designations please see page 53–54, table 12.2

Table 2.5

MTL Series						Lifting height			
						H32	H40	H48	H56
Fig.	Pos.	Name	Rope diameter	Reeving	Qty	Rope length			
						MTL312, MTL316			
2	18	Rope length, mm	ø 10 mm	2/1	1	68 500	84 600	–	116 800
						MTL525			
2	18	Rope length, mm	ø 12 mm	2/1	1	69 200	85 200	102 400	117 500

Table 2.6

MTL Series						Lifting height			
						H32	H40	H48	H56
Fig.	Pos.	Name		Qty	Catalog N°				
						MTL312, MTL316			
2	–	Bar set* (Pos. 7, 8, 9, 10, 11, 12, 13)		1					
2	8	Bar		1	812799	815266	–	815271	
2	10	Ring		2	573283	573283	–	573283	
2	7	Fork		1	809772	809772	–	809772	
2	11	Bolt M 6x25**		2	222029	222029	–	222029	
2	12	Pin DIN 94 2.5x14**		2	211986	211986	–	211986	
2		Spring washer**		1	805599	805599	–	805599	
2	9, 13	Nut M6**		3	843150	843150	–	843150	
2	–	Plate set (Pos. 4, 14, 15, 16)		1	810267	810267	–	810267	
2	4	Plate		1	810075	810075	–	810075	
2	15	Bolt**		2	805258	805258	–	805258	
2	14	Spring washer**		2	824894	824894	–	824894	
2	16	Nut**		2	808143	808143	–	808143	
2	5	End limit switch (KI G)		1	574478	574478	–	574478	
2	6	Cover for End limit switch		1	501573	501573	–	501573	
2	–	Screw**		2	219924	219924	–	219924	
						MTL525			
2	–	Bar set* (Pos. 7, 8, 9, 10, 11, 12, 13)		1					
2	8	Bar		1	815503	815504	815505	815506	
2	10	Ring		2	573283	573283	573283	573283	
2	7	Fork		1	808699	808699	808699	808699	
2	11	Bolt M 6x25**		2	222029	222029	222029	222029	
2	12	Pin DIN 94 2.5x14**		2	211986	211986	211986	211986	
2		Spring washer**		1	805599	805599	805599	805599	
2	9, 13	Nut M6**		3	843150	843150	843150	843150	
2	–	Plate set (Pos. 4, 14, 15, 16)		1	810267	810267	810267	810267	
2	4	Plate		1	810075	810075	810075	810075	
2	15	Bolt**		2	805258	805258	805258	805258	
2	14	Spring washer**		2	824894	824894	824894	824894	
2	16	Nut**		2	808143	808143	808143	808143	
2	5	End limit switch (KI G)		1	574478	574478	574478	574478	
2	6	Cover for End limit switch		1	501573	501573	501573	501573	
2	–	Screw**		2	219924	219924	219924	219924	

–* For DIN or BDS designations please see page 53–54, table 12.2

Table 3.1

Fig.	Pos.	Name	Qty	Catalog Nº		
				MT305, MT308	MT312, MT316	MT525
3	4-6	Bush set (reducer side)	1	811611	811612	811613
3	5	Bush (reducer side)	1	803137	803136	803135
3	6	Ring*	2	208726	208726	208726
3	4	Geared bush	2	811343	811343	811343
3	4-7	Bush set (motor side)***	1	807506	807506	807561
3	7	Bush (motor side)	1	807507	807507	803134
3	6	Ring*	2	208726	208726	804695
3	8	Protector**	1	803140	803140	803140
3		Shaft (set)	1	See table 3.2		

– * For DIN or BDS designations please see page 53–54, table 12.2

– ** The protector is mounted only in motor side.

– *** When you order Bush set (motor side) please indicate the type of the motor.

Table 3.2

Fig.	Pos.	Name	Qty	Lifting height			
				H0	H1	H2	H3
				Catalog Nº			
				MT305, MT308			
3	1-3	Shaft (set)	1	808396	807622	808030	808398
3	1	Shaft	1	808389	807623	807994	808390
3	2	Toothed disk	2	811381	811381	811381	811381
3	3	Ring*	4	809239	809239	809239	809239
				MT312, MT316			
3	1-3	Shaft (set)	1	808401	503349	503350	808402
3	1	Shaft	1	808393	503355	503356	808394
3	2	Toothed disk	2	811381	811381	811381	811381
3	3	Ring*	4	809239	809239	809239	809239
				MT525			
3	1-3	Shaft (set)	1	808401	503349	503350	808402
3	1	Shaft	1	808393	503355	503356	808394
3	2	Toothed disk	2	811381	811381	811381	811381
3	3	Ring*	4	809239	809239	809239	809239

– * For DIN or BDS designations please see page 53–54, table 12.2

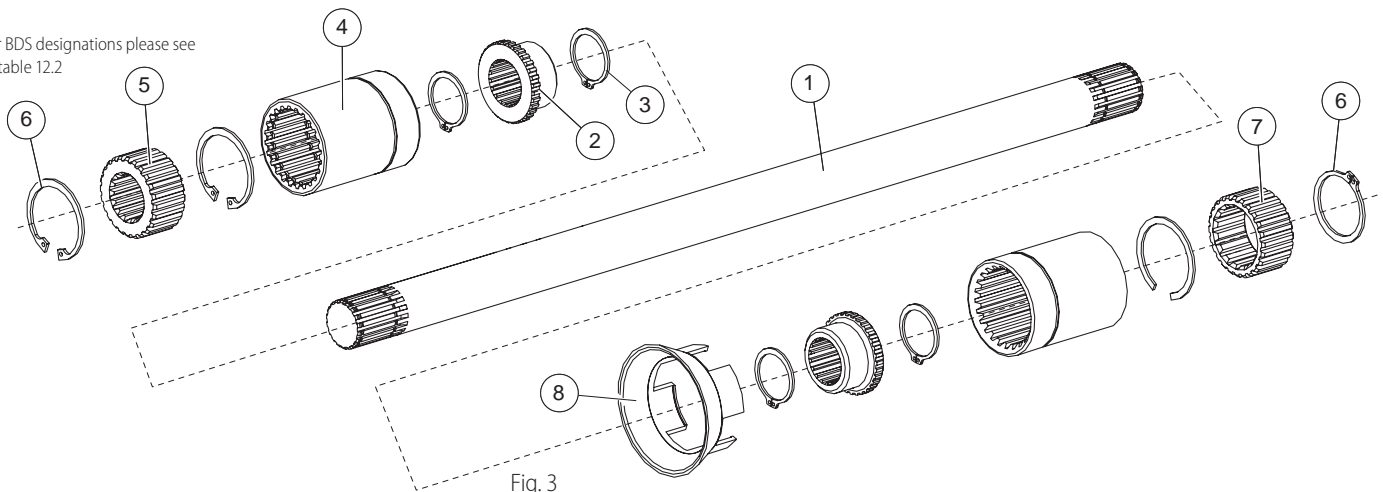

Table 4.1

Reeving 2/1 и 4/1				Rope diameter		
				ø 7 mm	ø 10 mm	ø 12 mm
Fig.	Pos.	Name	Qty	Catalog №		
				MT305, MT308	MT312, MT316, MTL312, MTL316	MT525, MTL525
4 a	1-10	Rope guide set (metal)	1	809151	809152	809153
4 a	10	Spring	1	202817	807146	202818
4 a	1	Nut set	1	809154	809155	809156
4 a	2	Guide set	1	809160	809161	809163
4 a	3	Bolt*	4	805062	805062	805062
4 a	4	Spring washer*	4	805599	805599	805599
4 a	5	Bearing*	2	581967	581967	581967
4 a	6	Ring*	2	225033	225033	225033
4 a	7	Plate	1	809255	809254	809255
4 b	1-10	Rope guide set (plastic)	1	–	810523	–
4 b	10	Spring	1	–	807146	–
4 b	1	Nut set	1	–	810588	–
4 b	2	Guide set	1	–	809161	–
4 b	3	Bolt*	4	–	805062	–
4 b	4	Spring washer*	4	–	805599	–
4 b	5	Bearing*	2	–	581967	–
4 b	6	Ring*	2	–	225033	–
4 b	7	Plate	1	–	809254	–

– In hoists type MT312, MT316, MTL312 and MTL316 the standard rope guide is plastic.

– On request, metal rope guide can be installed.

– * For DIN or BDS designations please see page 53–54, table 12.2

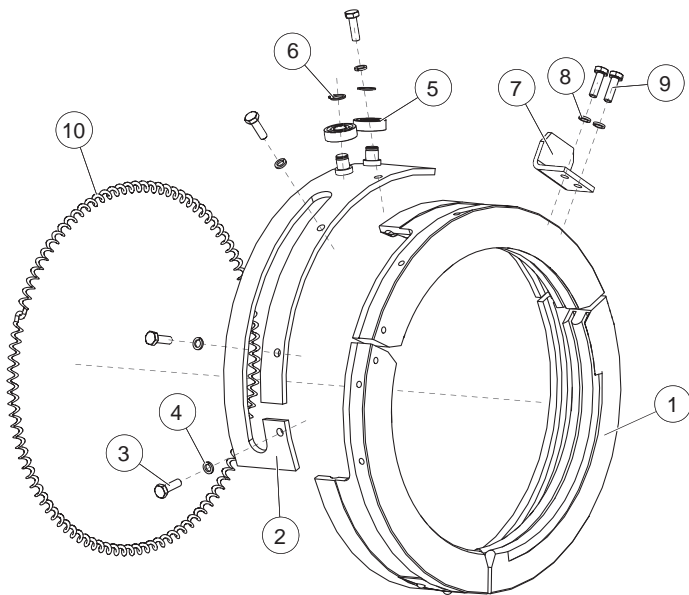

Fig. 4 a

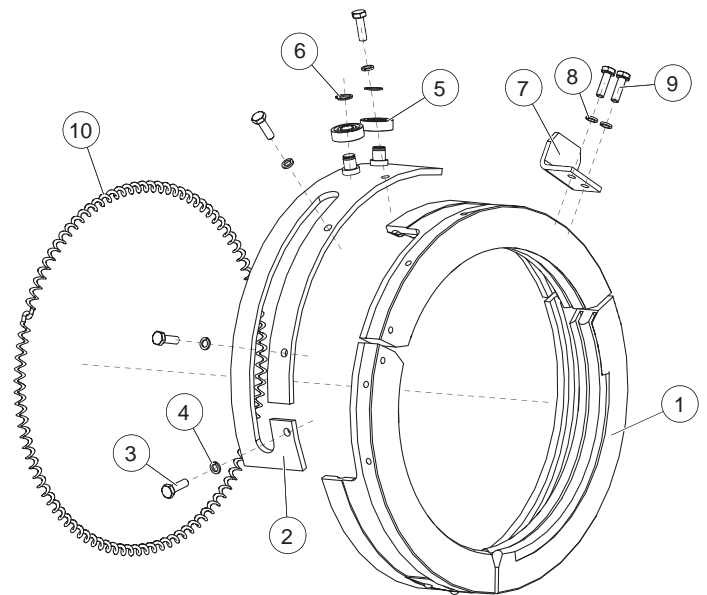

Fig. 4 b

Table 5.1

Hoists with Load Limiter Type HOT and without Load Limiter					Rope diameter				
					ø 7 mm	ø 7 mm	ø 10 mm	ø 10 mm	ø 12 mm
Fig.	Pos.	Name	Qty	Catalog №					
				MT305	MT308	MT312	MT316	MT525	
5	1	Wedge bush	1	260197	260199	260199	260199	260200	
5	2	Wedge	1	260209	009463	009463	009463	203523	
5	3	Carrier	1	826824	826784	826784	826784	808827	
5	3	Carrier (in hoists without load limiter)		826824	826784	826784	826784	827747	
5	4	Axle	1	832128	832130	832130	832130	832131	
5	6	Washer*	1	577620	806377	806377	806377	806377	
5	5	Nut*	1	804605	805542	805542	805542	805542	
5	7	Pin*	1	577625	824168	824168	824168	824168	
5	8	Axle HOT	1	577140	577142	577142	577142	577143	
5	8	Axle without HOT	1	832122	832126	832126	832126	832127	
5	9	Clamp	1	805131	805131	828151	828151	841462	

– * For DIN or BDS designations please see page 53–54, table 12.2

Table 5.2

Hoists with Dynamometric Pin					Rope diameter				
					ø 7 mm	ø 7 mm	ø 10 mm	ø 10 mm	ø 12 mm
Fig.	Pos.	Name	Qty	Catalog №					
				MT305	MT308	MT312, MTL312	MT316, MTL316	MT525, MTL525	
5	1	Wedge bush	1	810850	810850	810850	810850	260200	
5	2	Wedge	1	009463	009463	260211	260211	203523	
5	12	Carrier	1	810772	810772	810772	810772	810882	
5	4	Axle	1	810099	810099	810099	810099	810099	
5	6	Washer*	1	806377	806377	806377	806377	806377	
5	5	Nut*	1	805542	805542	805542	805542	805542	
5	7	Pin*	1	577626	577626	577626	577626	577626	
5	9	Clamp	1	805131	805131	828151	828151	841462	

– * For DIN or BDS designations please see page 53–54, table 12.2

Table 5.3

Fig.	Pos.	Name	Qty	Rope diameter		
				ø 10 mm	ø 10 mm	ø 12 mm
				MTL312	MTL316	MTL525
5	1	Wedge bush	1	260199	260199	260200
5	4	Wedge	1	009463	009463	203523
5	3	Carrier	1	826784	826784	808827
5	4	Axle	1	832130	832130	832131
5	12	Carrier for dynamometric pin	1	810772	810772	810882
5	4	Axle (In hoists with dynamometric pin)	1	810099	810099	810099
5	6	Washer*	1	806377	806377	806377
5	5	Nut*	1	805542	805542	805542
5	7	Pin*	1	824168	824168	824168
5	8	Axle HOT	1	577142	577142	577143
5	8	Axle without HOT	1	–	–	–
5	9	Clamp	1	828151	828151	841462

– * For DIN or BDS designations please see page 53–54, table 12.2

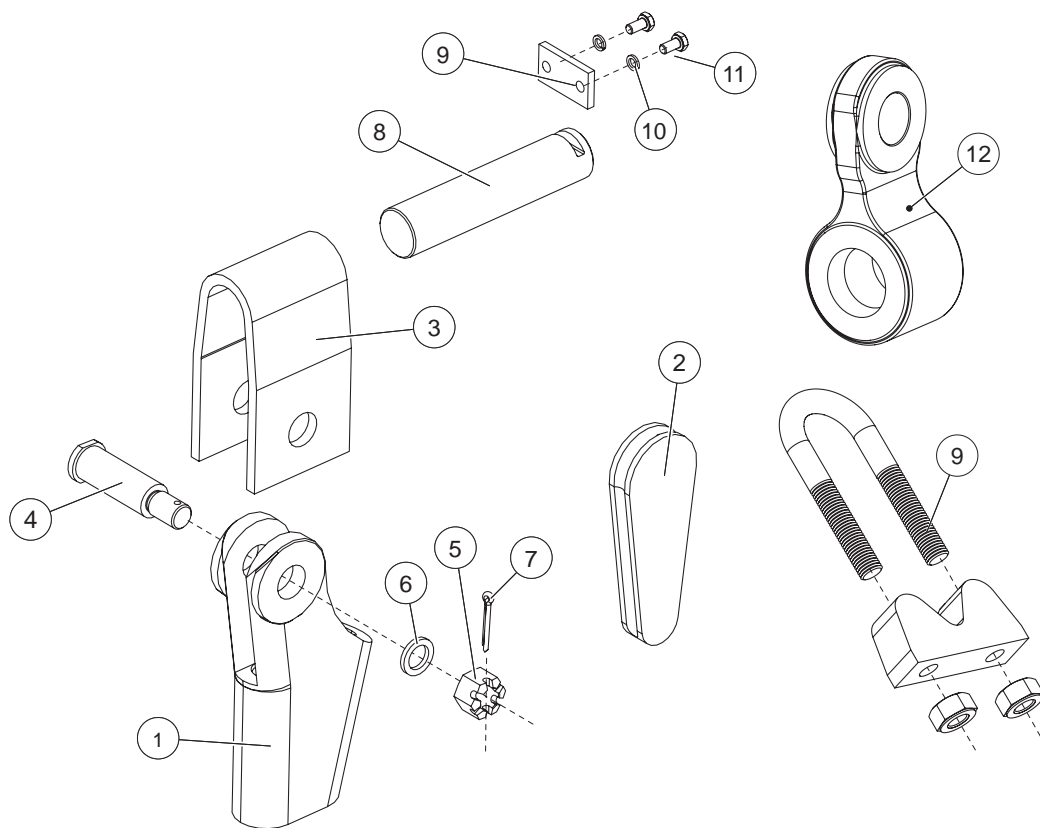

Fig. 5

Table 6.1

Load Limiter

Reeving 4/1

Fig.	Pos.	Name	Qty	Catalog №		
				MT305	MT308, MT312, MT316	MT525
6 a	5	Piston	1	577130	810717	577132
6 a	9	Plate 1	1	577176	577505	838075
6 a	13	Fixing plate	1	577139	577139	577139
6 a	12	Axle	1	577141	577142	577143
6 a	7	Bolt**	2	577153	577153	577153
6 a	8	Nut**	2	577154	577154	577154
6 a	10, 15	Bolt M6 x 12**	4	805328	805328	805328
6 a	11, 14	Spring washer**	4	805599	805599	805599
6 a	6	Spring**	*	578435	578436	578437
6 a	2	Screw**	2	809913	809913	809913
6 a	1	HOT cover	1	503310	503310	503312
6 a	3	End limit switch	2	578075	578075	578075
6 a	4	End limit switch cover	2	578076	578076	578076

– * Quantity of springs pos. 6:

- 8 pcs. for MT305
- 6 pcs. for MT308, MT312, MTL312
- 16 pcs. for MT316, MTL316
- 12 pcs. for MT525, MTL525.

– ** For DIN or BDS designations please see page 53–54, table 12.2

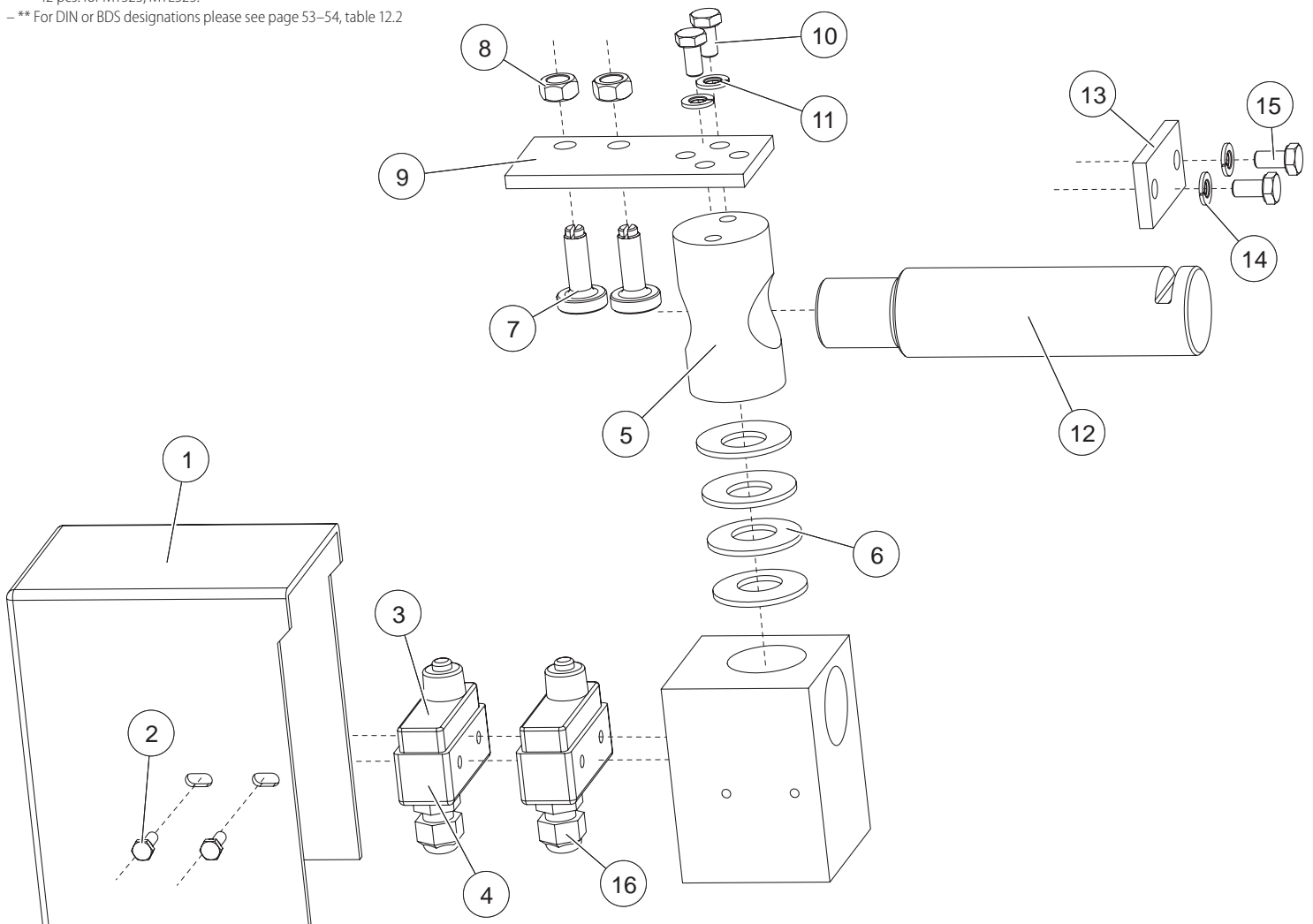

Fig. 6 a

Table 6.2

Load Limiter						
Reeving 2/1						
Fig.	Pos.	Name	Qty	Catalog №		
				MT305	MT308, MT312, MTL312, MT316, MTL316	MT525, MTL525
6 a	5	Piston	1	577130	810717	577132
6 a	9	Plate 1	1	577134	577135	577136
6 a	13	Fixing plate	1	577139	577139	577139
6 a	12	Axle	1	577140	577142	577143
6 a	7	Bolt**	2	577153	577153	577153
6 a	8	Nut**	2	577154	577154	577154
6 a	10, 15	Bolt M6 x 12**	4	805328	805328	805328
6 a	11, 14	Spring washer**	4	805599	805599	805599
6 a	6	Spring**	*	578435	578436	578437
6 a		Screw**	2	504944	809913	809913
6 a	1	HOT cover	1	807123	807123	807125
6 a	3	End limit switch	2	578075	578075	578075
6 a	4	End limit switch cover	2	578076	578076	578076

– * Quantity of springs pos. 6:

– 8 pcs. for MT305

– 6 pcs. for MT308, MT312, MTL312

– 16 pcs. for MT316, MTL316

– 12 pcs. for MT525, MTL525.

– ** For DIN or BDS designations please see page 53–54, table 12.2

Table 6.3

Dynamometric Pin								
Reeving 2/1 и 4/1								
Fig.	Pos.	Name	Qty	Catalog №				
				MT305	MT308	MT312, MTL312	MT316, MTL316	MT525, MTL525
6 b		Dynamometric pin**	1	505587	505587	505587	505587	505587
6 b		Fixing plate	1	802646	802646	802646	802646	802646
6 b		Bolt*	2	805062	805062	805062	805062	805062
6 b		Spring washer*	2	805559	805559	805559	805559	805559

– * For DIN or BDS designations please see page 53–54, table 12.2

– ** The dynamometric pin is the same for all types of hoists. For different lifting capacity the settings are different.

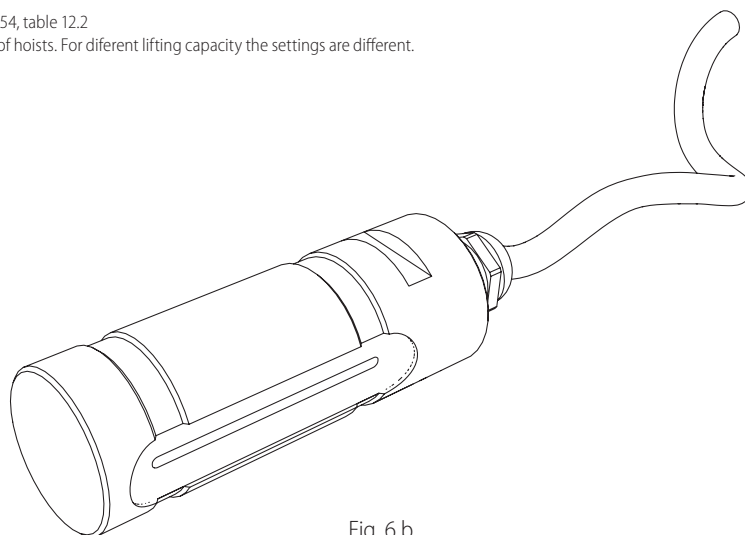

Fig. 6 b

Table 7.1

Normal Headroom				Lifting height											
				H1	H2	H3	H1	H2	H3	H1	H2	H3			
				Rope diameter											
				ø 7 mm			ø 7 mm			ø 10 mm			ø 12 mm		
Fig.	Pos.	Name	Qty	Catalog Nº											
				MT305			MT308			MT312, MT316			MT525		
7	1-9	Traverse with block roller (set)	1	814404	–	814404	814448	814448	814448	814375	814375	814375	813898	813898	813898
7	1-9	Traverse with block roller (set)	1	808264 ¹	–	808266 ¹	503450 ¹	503451 ¹	808227 ¹	503470 ¹	503471 ¹	808244 ¹	503314 ¹	503317 ¹	808245 ¹
7	8	Bolt*	2	805062	–	805062	805214	805214	805214	805214	805214	805214	805214	805214	805214
7	9	Spring washer*	2	805599	–	805599	824894	824894	824894	824894	824894	824894	824894	824894	824894
7	7	Fixing plate	1	203760	–	203760	203762	203762	203762	203762	203762	203762	203762	203762	203762
7	6	Axle	1	203755	–	203755	203759	203759	203759	203756	203756	203756	203757	203757	203757
7	5	Traverse	1	814410	–	814410	814449	814449	814449	814375	814376	814376	813899	813899	813899
7	5	Traverse	1	808267 ²	–	808269 ²	503452 ²	503453 ²	808228 ²	503472 ²	503473 ²	808242 ²	503315 ²	503316 ²	808243 ²
7	10	Bush	1	828301	–	828301	828301	828301	828301	828788	828788	828788	813904	813904	813904
7	10	Bush	1	814480 ³	–	814480 ³	814480 ³	814480 ³	814480 ³	814481 ³	814481 ³	814481 ³	808847 ³	808847 ³	808847 ³
7	1-4	Block roller	1	826715	826715	826715	830115	830115	830115	826717	826717	826717	830116	830116	830116
7	1	Roller	1	826839	826839	826839	830124	830124	830124	827245	827245	827245	830125	830125	830125
7	4	Ring*	2	208707	208707	208707	825051	825051	825051	208709	208709	208709	577649	577649	577649
	3	Bush	2	826835	826835	826835	826795	826795	826795	826766	826766	826766	827751	827751	827751
	2	Bearing*	1	208873	208873	208873	206041	206041	206041	825060	825060	825060	824451	824451	824451

- 1: Manufactured before 2012. Indicate year of manufacture and serial number of hoist.
- 2: Manufactured before 2012. Indicate year of manufacture and serial number of hoist.
- 3: Manufactured before 2012. Indicate year of manufacture and serial number of hoist.
- * For DIN or BDS designations please see page 53–54, table 12.2

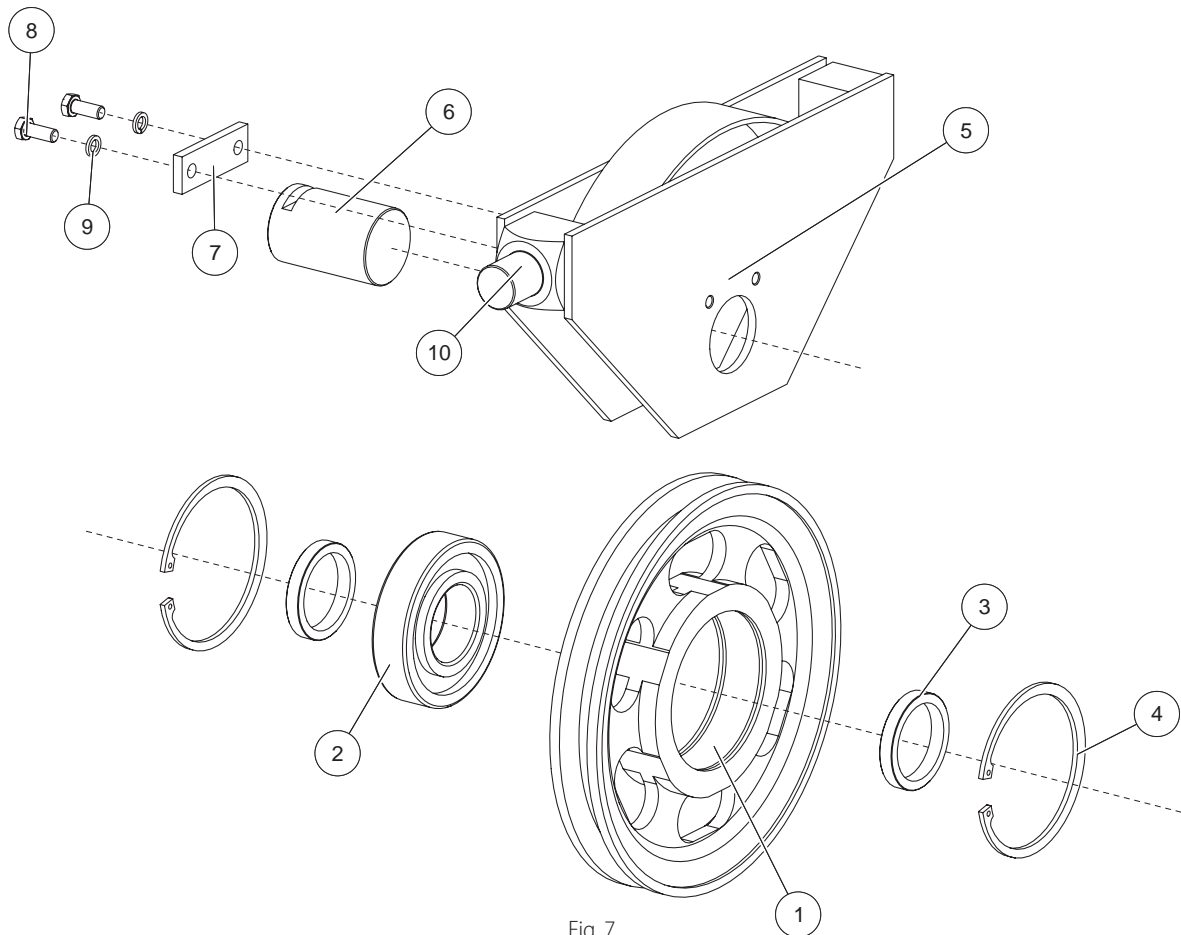

Fig. 7

Table 7.2												
Low Headroom				Lifting height								
				H1	H2	H3	H1	H2	H3	H1	H2	H3
				Rope diameter								
				ø 7 mm			ø 10 mm			ø 12 mm		
Fig.	Pos.	Name	Qty	Catalog Nº								
				MT305, MT308			MT312, MT316			MT525		
7	1-9	Traverse with block roller (set)	1	807424	807425	807608	807426	807427	807609	807428	807429	807610
7	8	Bolt*	2	805214	805214	805214	805214	805214	805214	805214	805214	805214
7	9	Spring washer*	2	824894	824894	824894	824894	824894	824894	824894	824894	824894
7	7	Fixing plate	1	203762	203762	203762	203762	203762	203762	203762	203762	203762
7	6	Axle	1	203759	203759	203759	203756	203756	203756	203757	203757	203757
7	5	Traverse	1	807416	807417	807612	807418	807419	807613	807420	807421	807614
7		Bush	1	828301	828301	828301	828788	828788	828788	815984	815984	815984
7	1-4	Roller set	1	830115	830115	830115	826717	826717	826717	830116	830116	830116
7	1	Roller	1	830124	830124	830124	827245	827245	827245	830125	830125	830125
7	4	Ring*	2	825051	825051	825051	208709	208709	208709	577649	577649	577649
7	3	Bush	2	826795	826795	826795	826766	826766	826766	827751	827751	827751
7	2	Bearing*	1	206041	206041	206041	825060	825060	825060	824451	824451	824451

– * For DIN or BDS designations please see page 53–54, table 12.2

Table 8.1								
Reeving 2/1				Load capacity				
				1 t	1.6 t	2.5 t	3.2 t	5 t
				Rope diameter				
				ø 7 mm	ø 7mm	ø 10 mm	ø 10 mm	ø 12 mm
Fig.	Pos.	Name	Qty	Catalog N ^o				
				MT305	MT308	MT312, MTL312	MT316, MTL316	MT525, MTL525
8 a	1-22	Block hook - FEM 2m	1	809140	809141	809142	809142	809144
8 a	1-8	Hook with traverse	1	836902	836904	836906	836906	836908
8 a	1	Hook	1	826067	826833	826615	826615	826250
8 a	3	Traverse	1	827716	827717	826490	826490	826491
8 a	4	Nut	1	827199	826256	826494	826494	826495
8 a	2	Bearing*	1	800510	800511	206406	206406	206407
8 a		Spring pin	1	828161	827560	828164	828164	827561
8 a	5-8	Latch set	1					
8 a	5	Latch	1	836883	836886	836885	836885	836884
8 a	6	Spring	1	836891	836890	836890	836890	836889
8 a	7	Bolt*	1	805429	805215	805215	805215	805215
8 a	8	Nut	1	804824	804824	804824	804824	804824
8 a	9-11	Block roller	1	826715	830115	826717	826717	830116
8 a	9	Roller	1	826839	830124	827245	827245	830125
8 a	10	Bearing*	1	208873	206041	825060	825060	824451
8 a	11	Ring*	2	208707	825051	208709	208709	577649
8 a	19	Plate	2	827703	801500	801501	801501	838100
8 a	12	Profile	-	-	-	-	-	826971
8 a	13	Profile	-	-	-	-	-	826972
8 a	13	Rubber profile	1	810360	812699	812700	812700	-
8 a	12	Rubber profile	1	812769	812697	812698	812698	-
8 a	14	Cover	2	826903	827707	827708	827708	827709
8 a	18	Axle	1	827710	827711	826488	826488	826489
8 a	20	Bush	2	837573	837574	-	-	837576
8 a	16	Screw*	2	581545	575763	575764	575764	575765
8 a	15	Ring*	2	208708	208721	208734	208734	208734
8 a	17	Nut	2	208489	208490	208491	208491	208491
8 a	21	Plate	2	-	-	-	-	-
8 a	22	Screw	8	-	-	-	-	--

- * For DIN or BDS designations please see page 53-54, table 12.2

Block Hook Reeving 2/1

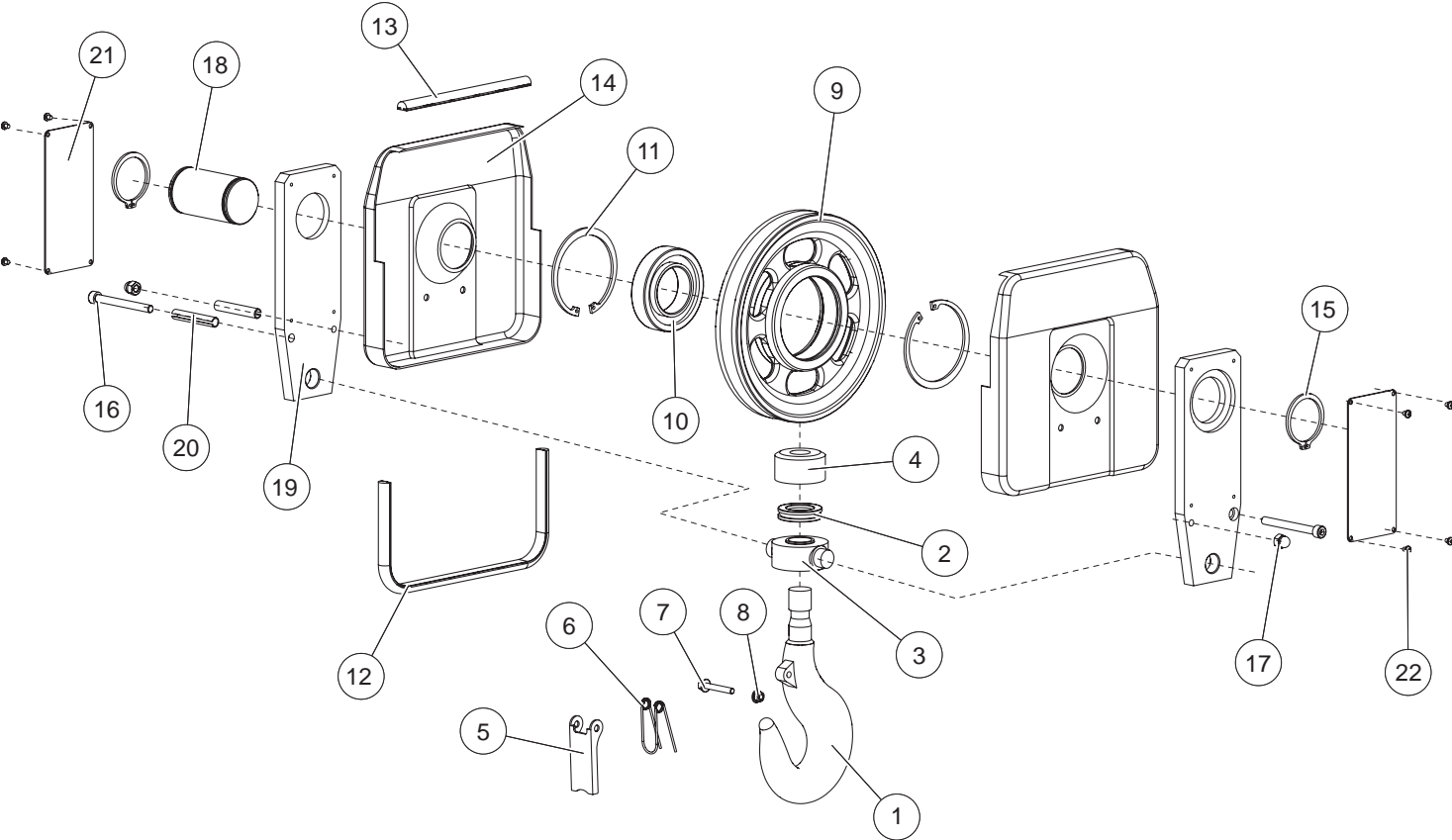

Fig. 8 a

Table 8.2								
Reeving 4/1				Load capacity				
				2 t	3.2 t	5 t	6.3 t	10 t
				Rope diameter				
				ø 7 mm	ø 7mm	ø 10 mm	ø 10 mm	ø 12 mm
Fig.	Pos.	Name	Qty	Catalog №				
				MT305	MT308	MT312	MT316	MT525
8 b	1-20	Block Hook – FEM 2m	1	809145	809146	809147	809148	809149
8 b	1-8	Hook with traverse	1	836906	836906	836927	836924	808380
8 b	1	Hook	1	826615	826615	826250	826760	808381
8 b	3	Traverse	1	826490	826490	826789	826492	828391
8 b	2	Nut	1	826494	826494	826495	826496	826496
8 b	4	Bearing*	1	206406	206406	206407	210578	210578
8 b	–	Spring pin	1	828164	828164	827561	827562	827562
8 b	5-8	Latch set	1	–	–	–	–	–
8 b	5	Latch	1	836885	836885	836884	836884	836884
8 b	6	Spring	1	836890	836890	836890	836889	836889
8 b	7	Bolt*	1	805215	805215	805215	805215	805215
8 b	8	Nut	1	804824	804824	804824	804824	804824
8 b	13	Plate	2	809749	830151	809750	809751	828397
8 b	9-11	Block roller	2	826715	830115	826762	826762	827750
8 b	10	Bearing*	2	208873	206041	206041	206041	825060
8 b	11	Ring*	4	208707	825051	825051	825051	208709
8 b	16	Ruber profile	2	812769	812697	812698	812698	826971
8 b	17	Ruber profile	2	812771	812699	812700	812700	826972
8 b	–	Bush	2	826830	830177	–	–	–
8 b	12	Axle	1	833864	830178	826498	826498	826965
8 b	15	Cover	4	834582	827707	826757	826757	826967
8 b	18	Ring*	2	208708	208721	208721	208721	208734
8 b	–	Spring washer*	4	805599	805599	805599	805599	805570
8 b	14	Bolt*	4	805328	805328	805328	805328	805232

– * For DIN or BDS designations please see page 53–54, table 12.2

Block Hook Reeving 4/1

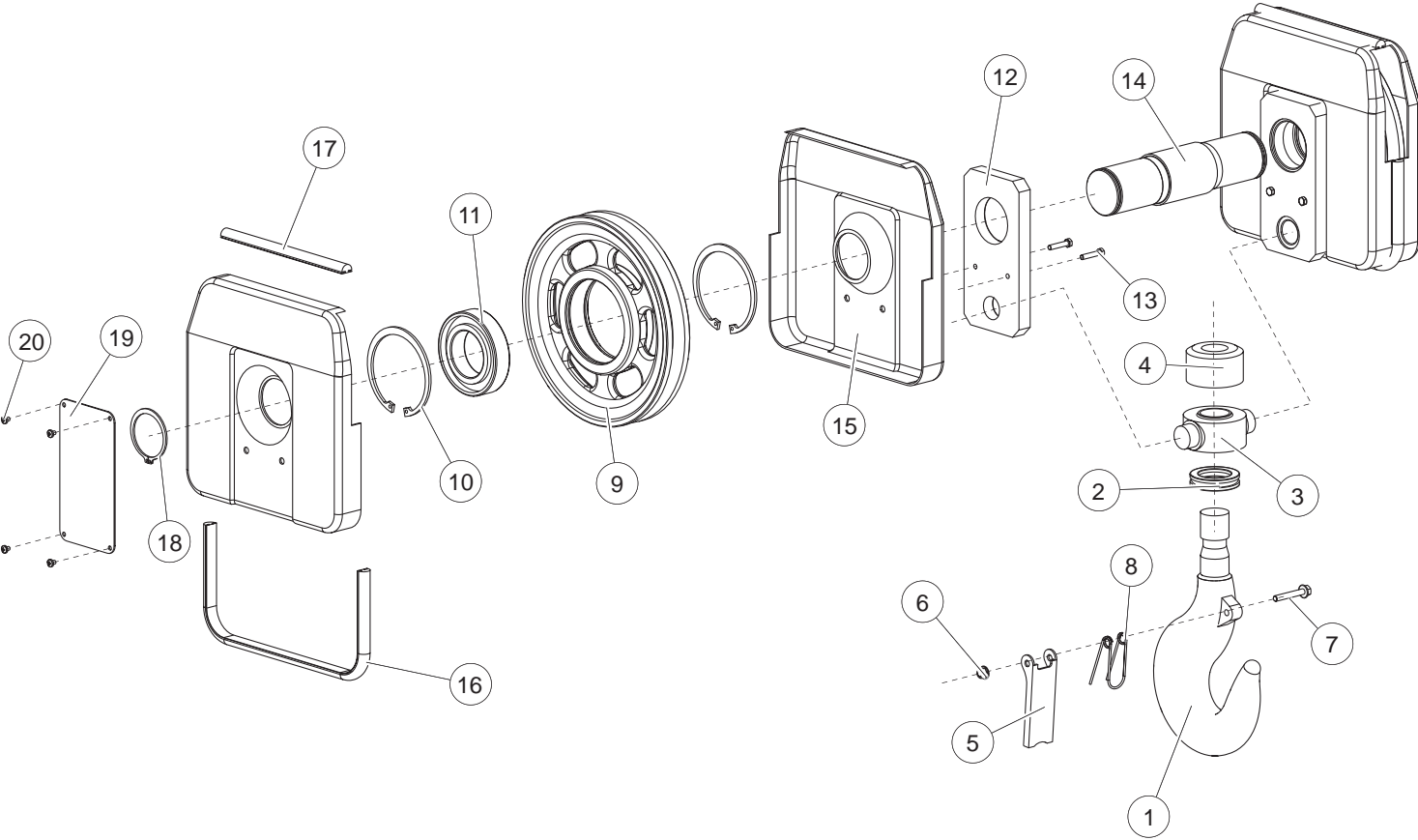

Fig. 8 b

Table 9.1

Reeving 2/1		Travel wheel diameter				
		ø 125 mm				
Fig.	Pos.	Name	Qty	Catalog №		
				MT305, MT308	MT312, MT316	MT525
9 a		Driven block set (left) (Pos. 2, 3, 4, 5, 6, 7, 12) (For profile with universal slope)	1	808725	808725	808729
9 a		Driven block set (left) (Pos. 2, 3, 4, 5, 6, 7, 12) (For profile with zero slope)	1	807380	807380	808241
9 a	3-5	Driven wheel set – Universal slope	1	831718	831718	808715
9 a	3	Driven wheel – Universal slope	1	829296	829296	808713
9 a	3-5	Driven wheel set – Zero slope	1	835558	835558	807451
9 a	3	Driven wheel – Zero slope	1	835570	835570	807489
9 a	12	Carrier (left)	1	807376	807376	808240
9 a	5	Ring*	1	208738	208738	211941
9 a	4	Bearing*	2	825569	825569	224215
9 a	7	Axle	1	831710	831710	835608
9 a	6	Bush	1	831712	831712	832035
9 a	2	Ring*	1	205639	205639	208719
9 a		Bolt*	1	250800	250800	825839
9 a		Bolt*	1	804901	229169	829470
9 a		Washer*	2	211974	211974	823925
9 a		Nut*	2	800914	800914	219202
9 a		Washer*	1	812682	812682	504757
9 a		Driven block set (right) (Pos. 2-8) (For profile with universal slope)	1	808720	808720	808724
9 a		Driven block set (right) (Pos. 2-8) (For profile with zero slope)	1	807388	807388	808221
9 a	3-5	Driven wheel set – Universal slope	1	831718	831718	808715
9 a	3	Driven wheel – Universal slope	1	829296	829296	808713
9 a	3-5	Driven wheel set – Zero slope	1	835558	835558	807451
9 a	3	Driven wheel – Zero slope	1	835570	835570	807489
9 a	8	Carrier (right)	1	807384	807384	808213
9 a	5	Ring*	1	208738	208738	211941
9 a	4	Bearing*	2	825569	825569	224215
9 a	7	Axle	1	831710	831710	835608
9 a	6	Bush	1	831712	831712	832035

Continued on next page >

Table 9.1

Reeving 2/1				Travel wheel diameter		
				ø 125 mm		
Fig.	Pos.	Name	Qty	Catalog №		
				MT305, MT308	MT312, MT316	MT525
9 a	2	Ring*	1	205639	205639	208719
9 a		Bolt*	1	250800	250800	825829
9 a		Bolt*	1	804901	229169	829470
9 a		Washer*	2	211974	211974	823925
9 a		Nut*	2	800914	800914	219202
9 a		Washer	1	812682	812682	504575
9 a		Driving block set (left) (Pos. 1, 17, 14, 15, 13, 19) (For profile with universal slope)	1	808730	808730	808731
9 a		Driving block set (left) (Pos. 1, 17, 14, 15, 13, 19) (For profile with zero slope)	1	807396	807396	807397
9 a	13-15	Driving wheel (set) – Universal slope	1	831719	831719	808718
9 a	13	Driving wheel – Universal slope	1	829297	829297	808717
9 a	13-15	Driving wheel (set) – Zero slope	1	835552	835552	807453
9 a	13	Driving wheel – Zero slope	1	835564	835564	807484
9 a	1	Carrier (left)	1	807392	807392	807393
9 a	15	Ring*	1	208738	208738	211941
9 a	14	Bearing*	2	825569	825569	224215
9 a		Axle	1	826508	826508	807491
9 a	19	Bush	1	827954	827954	827469
9 a	17	Bush	1	828786	828786	828787
9 a		Ring*	1	205639	205639	208719
9 a	16	Shaft	1	829802	829802	807493
		Ring 190	1	827814	827814	827814
9 a		Driving block right (Pos. 17-19) (For profile with universal slope)	1	808734	808734	808735
9 a		Driving block right (Pos. 17-19) (For profile with zero slope)	1	807404	807404	807405
9 a	13-15	Driving wheel (set) – Universal slope	1	831719	831719	808718
9 a	13	Driving wheel – Universal slope	1	829297	829297	808717
9 a	13-15	Driving wheel (set) – Zero slope	1	835552	835552	807453
9 a	13	Driving wheel – Zero slope	1	835564	835564	807484
9 a	18	Carrier (right)	1	807400	807400	807401

Table 9.1

Reeving 2/1		Travel wheel diameter				
		ø 125 mm				
Fig.	Pos.	Name	Qty	Catalog N°		
				MT305, MT308	MT312, MT316	MT525
9 a	15	Ring*	1	208738	208738	211941
9 a	14	Bearing*	2	825569	825569	224215
9 a		Axle	1	826508	826508	807491
9 a	19	Bush	1	827954	827954	827469
9 a	17	Bush	1	828786	828786	828787
9 a		Ring*	1	205639	205639	208719
9 a	16	Shaft	1	829802	829802	807493
		Ring 190	1	827814	827814	827814

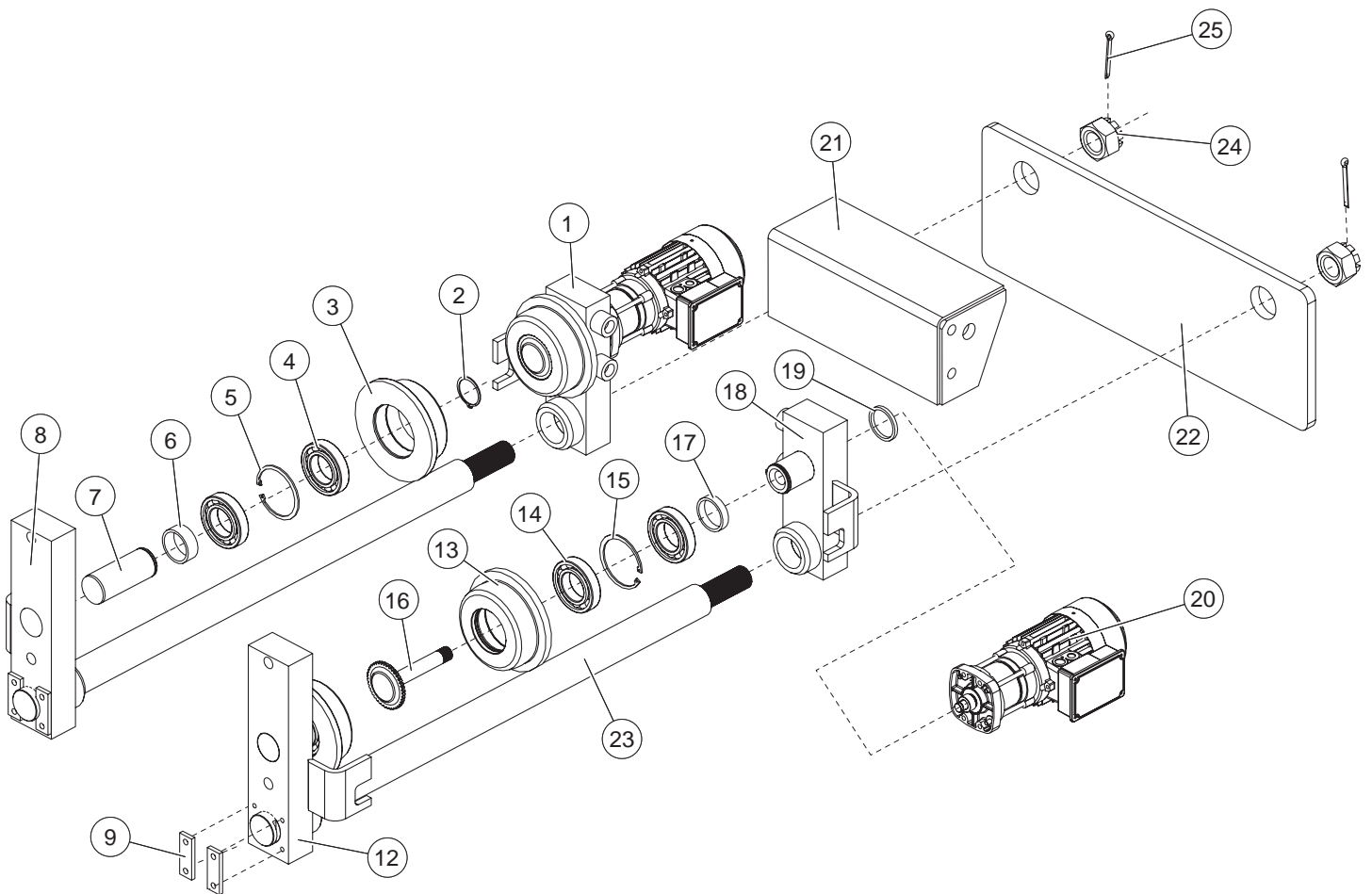

Fig. 9 a

Table 9.2

Reeving 4/1		Travel wheel diameter				
		ø 160 mm				
Fig.	Pos.	Name	Qty	Catalog №		
				MT305, MT308	MT312, MT316	MT525
9 a		Driven block left (left) (Pos. 2, 3, 4, 5, 6, 7, 12) (For profile with universal slope)	1	808725	808726	808728
9 a		Driven block left (left) (Pos. 2, 3, 4, 5, 6, 7, 12) (For profile with zero slope)	1	807380	807381	807383
9 a	3-5	Driven wheel set – Universal slope	1	831718	808715	808716
9 a	3	Driven wheel – Universal slope	1	829296	808713	808714
9 a	3-5	Driven wheel set – Zero slope	1	835558	807451	807452
9 a	3	Driven wheel – Zero slope	1	835570	807489	807490
9 a	12	Carrier (left)	1	807376	807377	807379
9 a	5	Ring*	1	208738	211941	221394
9 a	4	Bearing*	2	825569	224215	228378
9 a	7	Axle	1	831710	835608	810117
9 a	6	Bush	1	831712	832035	807454
9 a	2	Ring*	1	205639	208719	208736
9 a		Bolt*	1	250800	825829	825829
9 a		Bolt*	1	804901	829470	576872
9 a		Washer*	2	211974	823925	823925
9 a		Nut*	2	800914	219202	219202
9 a		Washer*	1	812682	–	–
9 a		Driven block right (set) (Pos. 2-8) (For profile with universal slope)	1	808720	808721	808723
9 a		Driven block right (set) (Pos. 2-8) (For profile with zero slope)		807388	807389	807391
9 a	3-5	Driven wheel set – Universal slope	1	831718	808715	808716
9 a	3	Driven wheel – Universal slope	1	829296	808713	808714
9 a	3-5	Driven wheel set – Zero slope	1	835558	807451	807452
9 a	3	Driven wheel – Zero slope	1	835570	807489	807490
9 a	8	Carrier (right)	1	807384	807385	807387
9 a		Ring*	1	208738	211941	221394
9 a	4	Bearing*	2	825569	224215	228378
9 a	7	Axle	1	831710	835608	810117
9 a	6	Bush	1	831712	832035	807454

Table 9.2

Reeving 4/1				Travel wheel diameter		
				ø 125 mm	ø 125 mm	ø 160 mm
Fig.	Pos.	Name	Qty	Catalog N°		
				MT305, MT308	MT312, MT316	MT525
9 a	2	Ring*	1	205639	208719	208736
9 a		Bolt*	1	250800	825829	825829
9 a		Bolt*	1	804901	829470	576872
9 a		Washer*	2	211974	823925	823925
9 a		Nut*	2	800914	219202	219202
9 a		Washer	1	812682	-	-
9 a		Driving block left (set) (Pos. 1, 17, 14, 15, 13, 19) (For profile with universal slope)	1	808730	808731	808733
9 a		Driving block left (set) (Pos. 1, 17, 14, 15, 13, 19) (For profile with zero slope)	1	807396	807397	807399
9 a	13-15	Driving wheel (set) – Universal slope	1	831719	808718	808719
9 a	13	Driving wheel – Universal slope	1	829297	808717	810910
9 a	13-15	Driving wheel (set) – Zero slope	1	835552	807453	807483
9 a	13	Driving wheel – Zero slope	1	835564	807484	810909
9 a	1	Carrier (left)	1	807392	807393	807395
9 a	15	Ring*	1	208738	211941	221394
9 a	14	Bearing*	2	825569	224215	228378
9 a		Axle	1	826508	807491	807492
9 a	19	Bush	1	827954	827469	827474
9 a	17	Bush	1	828786	828787	807495
9 a		Ring*	1	205639	208719	208736
9 a	16	Shaft	1	829802	807493	807494
		Ring 190	1	827814	827814	832427
9 a		Driving block (right) (Pos. 13-15, 17-19) (For profile with universal slope)	1	808734	808735	808737
9 a		Driving block (right) (Pos. 13-15, 17-19) (For profile with universal slope)	1	807404	807405	807407
9 a	13-15	Driving wheel (set) – Universal slope	1	831719	808718	808719
9 a	13	Driving wheel – Universal slope	1	829297	808717	810910
9 a	13-15	Driving wheel (set) – Zero slope	1	835552	807453	807483
9 a	13	Driving wheel – Zero slope	1	835564	807484	810909
9 a	18	Carrier (right)	1	807400	807401	807403

Continued on next page >

Table 9.2

Reeving 4/1		Travel wheel diameter				
		ø 125 mm	ø 125 mm	ø 160 mm		
Fig.	Pos.	Name	Qty	Catalog Nº		
			MT305, MT308	MT312, MT316	MT525	
9 a	15	Ring*	1	208738	211941	221394
9 a	14	Bearing*	2	825569	224215	228378
9 a		Axle	1	826508	807491	807492
9 a	19	Bush	1	827954	827469	827474
9 a	17	Bush	1	828786	828787	807495
9 a		Ring*	1	205639	208719	208736
9 a	16	Shaft	1	829802	807493	807494
		Ring 190	1	827814	827814	832427

– * For DIN or BDS designations please see page 53–54, table 12.2

Table 9.3

Suspension Reeving 2/1		Lifting height					
		H0	H1	H2	H3		
Fig.	Pos.	Name	Qty	Catalog Nº			
			MT305				
9 a	21	Frame for hoist with load limiter type HOT	1	808792	808793	–	–
9 a	21	Frame for hoist with dynamometric pin	1	–	–	–	–
9 a	21	Frame for hoist without load limiter	1	–	–	–	–
9 a	22	Counterweight	2	808658	808659	–	–
			MT308				
9 a	21	Frame for hoist with load limiter type HOT	1	808748	808749	808750	–
9 a	21	Frame for hoist with dynamometric pin	1	810790	810791	810792	810793
9 a	21	Frame for hoist without load limiter	1	–	–	–	–
9 a	22	Counterweight	2	808658	808659	808660	–
			MT312				
9 a	21	Frame for hoist with load limiter type HOT	1	808819	–	–	808822
9 a	21	Frame for hoist with dynamometric pin	1	–	810795	810796	810797
9 a	21	Frame for hoist without load limiter	1	–	–	–	–
9 a	22	Counterweight	2	808662	–	–	808665
			MT316				
9 a	21	Frame for hoist with load limiter type HOT	1	808939	808753	808754	811912
9 a	21	Frame for hoist with dynamometric pin	1	810794	810795	810796	810797
9 a	21	Frame for hoist without load limiter	1	813954	–	–	–
9 a	22	Counterweight	2	808662	808663	808664	808665
			MT525				
9 a	21	Frame for hoist with load limiter type HOT	1	808756	808757	808759	–
9 a	21	Frame for hoist with dynamometric pin	1	810802	810803	810804	810805
9 a	21	Frame for hoist without load limiter	1	–	–	–	–
9 a	22	Counterweight	3	815039	815036	815037	–

Table 9.4

Suspension Reeving 4/1		Lifting height				
		H1	H2		H3	
Fig.	Pos.	Name	Qty	Catalog N°		
				MT305, MT308		
9 a	21	Frame	1	807435	807444	807592
9 a	22	Counterweight	2	808659	808660	808661
				MT312, MT316		
9 a	21	Frame	1	807445	807446	807593
9 a	22	Counterweight	2	808870	808871	808872
				MT525		
9 a	21	Frame	1	807447	807448	807594
9 a	22	Counterweight	3	815036	815037	815038

Table 9.5

Suspension Reeving 2/1		Travel wheel diameter ø 125 mm				
		Catalog N°				
Fig.	Pos.	Name	Qty	MT305, MT308	MT312, MT316	MT525
9 a		Bush M323	4	828302	815834	828789
9 a		Bolt*	4	800913	800913	801245
9 a		Washer*	4	211973	211973	823925
9 a		Spring washer*	4	824894	824894	208248
9 a	23	Stud	2	811452	811452	811453
9 a		Bush	-	504536 ¹	504536 ¹	504538 ²
9 a		Washer*	12	148986	148986	204037
9 a		Washer AM 45*	2	842428	842428	842428
9 a	24	Nut*	2	825836	825836	825836
9 a	25	Pin*	2	211989	211989	211989
9 a	9	Plate	4	812679	812679	812679
9 a	10	Bolt*	8	805214	805214	805258
9 a	11	Washer*	8	812750	812750	812750

- 1: 72 pcs. bushes ø45 L12

- 2: 70 pcs. bushes ø55 L15

- * For DIN or BDS designations please see page 53–54, table 12.2

Table 9.6

Suspension Reeving 4/1		Travel wheel diameter				
		ø 125 mm		ø 125 mm	ø 155 mm	
Fig.	Pos.	Name	Qty	Catalog №		
			MT305, MT308	MT312, MT316	MT525	
9 a		Bush	4	828302	828789	829053
9 a		Bolt	4	800913	801245	800979
9 a		Washer*	4	211973	823925	202692
9 a		Spring washer*	4	824894	208248	208210
9 a	23	Stud	2	811452	811453	811454
9 a		Bush	4	204026	204027	204027
9 a		Bush	–	504536 ¹	504538 ²	504539 ³
9 a		Washer*	12	148986 ⁴	204037 ⁴	807570 ⁵
9 a		Washer AM 45*	2	842428	842428	842428
9 a	24	Nut*	2	825836	825836	825836
9 a	25	Pin*	2	211989	811989	211989
9 a	9	Plate	4	812679	812679	203762
9 a	10	Bolt*	8	805214	805214	805214
9 a	11	Washer*	8	811750	812750	812750

– 1: 72 pcs. bushes ø45 L12

– 2: 70 pcs. bushes ø55 L15

– 3: 48 pcs. bushes ø60 L30

– 4: 12 pcs. washers

– 5: 22 pcs. washers

– * For DIN or BDS designations please see page 53–54, table 12.2

Table 9.7

Gear Motor Reeving 2/1		Speed (m/min) — 20/5				
				MT305, MT308, MT312, MT316	MT525	
Fig.	Pos.	Name	Qty	Catalog №		
9 b	1-3	Gear motor	1	834484	834322	
9 b	1	Travel reducer	1	810029	809327	
9 b	2	Travel motor	1	582282	806509	
9 b	3	Stud	4	–	–	
		Grease			See table 9.9	

Table 9.8

Gear Motor						
Reeving 4/1						
Speed (m/min) — 20/5						
Fig.	Pos.	Name	Qty	Catalog №		
				MT305, MT308	MT312, MT316	MT525
9b	1-3	Gear motor	1	834484	834322	834337
9b	1	Travel reducer	1	810029	809327	809333
9b	2	Travel motor	1	582282	806509	806509
9b	3	Stud	4	–	–	–
		Grease			See table 9.9	

Gear Motor

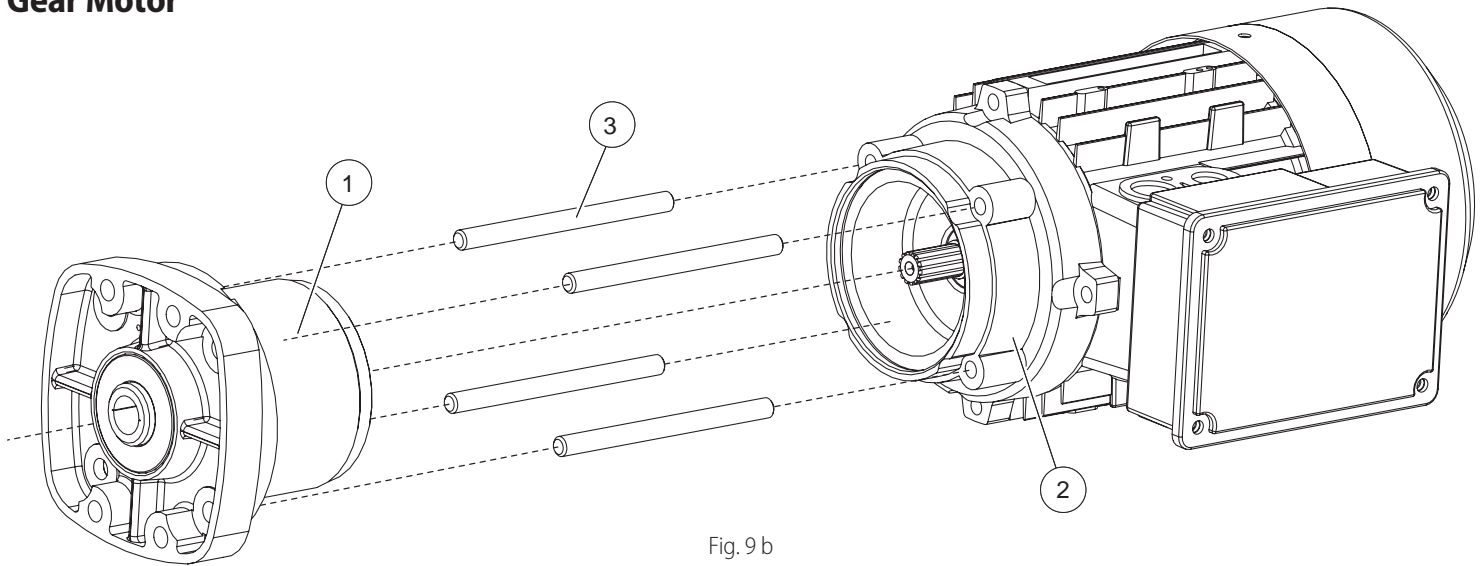

Table 9.9

Grease*				
	Reeving	Lifting speed (m/min)	Qty (kg)	Catalog №
MT305-308, MT312-316	2/1	20/5	0.07	809211
MT525	2/1	20/5	0.130	809211
MT305-308	4/1	20/5	0.07	809211
MT312-316	4/1	20/5	0.130	809211
MT525	4/1	20/5	0.130	809211

– * Podem recommend grease Total Ceran CA

Table 10.1

Lifting Motor (Cylindrical / Double Speed), 380–400 V, 50Hz

Lifting Speed – V1

Fig.	Pos.	Type	Reeving	Name / Type	P, kW	I, A	Speed rPM	Catalog №
10 a	6-11	MT304, MT305, MT306, MT308	2/1, 4/1	CT112M-12/4-240Tp1	0.83/2.5	5.9/6	430/1400	602099
10 a	8-10	Brake set		BR SET CT112 12/4	–	–	–	504419
10 a	8	Brake coil		MGN CT112	–	–	–	501206
10 a	10	Brake fan		BR FAN CT112	–	–	–	504464
10 a		Rectifier		ABR 2600	–	–	–	516092
10 a	6	Cover		COV CT112	–	–	–	505371
10 a	6-11	MT310, MT312	2/1, 4/1	CT132MA-12/4-240Tp1	1.33/4	8.3/9.2	450/1400	504009
10 a	8-10	Brake set		BR SET CT132 12/4	–	–	–	504466
10 a	8	Brake coil		MGN CT132	–	–	–	504033
10 a	10	Brake fan		BR FAN CT132	–	–	–	504045
10 a		Rectifier		ABR 2600	–	–	–	516092
10 a	6	Cover		COV CT132	–	–	–	505873
10 a	6-11	MT313, MT316	2/1, 4/1	CT132MB-12/4-240Tp1	1.66/5	9.6/11	460/1430	602101
10 a	8-10	Brake set		BR SET CT132 12/4	–	–	–	504466
10 a	8	Brake coil		MGN CT132	–	–	–	504033
10 a	10	Brake fan		BR FAN CT132	–	–	–	504045
10 a		Rectifier		ABR 2600	–	–	–	516092
10 a	6	Cover		COV CT132	–	–	–	505873
10 a	1-7	MT520, MT525	2/1, 4/1	MB 160MB-4/12 A2	2.6/8	14.5/17.7	435/1440	504073
10 a	1-3	Brake set		BRSET MB160 MB FDB 20	–	–	–	504207
10 a	2	Brake disc		BR DISC FDB 20	–	–	–	504225
10 a		Rectifier		PMG 500 S	–	–	–	806571
10 a	6	Cover		COV MB 160	–	–	–	505874
10 a	1-7	MT520, MT525	2/1, 4/1	CT 160M-12/4 KF7 290 TP1 380–400 V	2.7/8.5	16/15	1450/470	505506
10 a	1-3	Brake set		BR SET CT160 12/4 KF7	–	–	–	516096
10 a	2	Brake disc		BR DISK KF7	–	–	–	505854
10 a		Rectifier		ABR 2600	–	–	–	516092
10 a	6	Cover		BR COV CT160	–	–	–	505874
10 a	1-7	MT520, MT525	2/1, 4/1	DM 16-55-16/4 D649AK 380–400 V	7.8/1.9	18/10	1440/350	503550
10 a	1-3	Brake set		BR SET DM 1655 16/4	–	–	–	504999
10 a	2	Brake disc		BR DISC DM 1655-12/4	–	–	–	516089
10 a		Rectifier		PMG 500 S	–	–	–	806571
10 a	6	Cover		COV DM 16-55	–	–	–	505874

Table 10.2

Lifting Motor (Cylindrical / Double Speed), 380–400 V, 50Hz

Lifting Speed – V2

Fig.	Pos.	Type	Reeving	Name / Type	P, kW	I, A	Speed rPM	Catalog №
10 a	6-11	MT304, MT305	2/1, 4/1	CT112M-12/4-240Tp1	0.83/2.5	5.9/6	430/1400	602099
10 a	8-10	Brake set	–	BR SET CT112 12/4	–	–	–	504419
10 a	8	Brake coil	–	MGN CT112	–	–	–	501206
10 a	10	Brake fan	–	BR FAN CT112	–	–	–	504464
10 a		Rectifier	–	ABR 2600	–	–	–	516092
10 a	6	Cover	–	COV CT112	–	–	–	505371
10 a	6-11	MT306, MT308	2/1, 4/1	CT132MA-12/4-240Tp1	1.33/4	8.3/9.2	450/1400	504009
10 a	8-10	Brake set	–	BR SET CT132 12/4	–	–	–	806441
10 a	8	Brake coil	–	MGN CT132	–	–	–	504033
10 a	10	Brake fan	–	BR FAN CT132	–	–	–	504045
10 a		Rectifier	–	ABR 2600	–	–	–	516092
10 a	6	Cover	–	COV CT132	–	–	–	505873
10 a	6-11	MT310, MT312	2/1, 4/1	CT132MB-12/4-240-6Tp1	2/6	10/13	460/1430	504052
10 a	8-10	Brake set	–	BR SET CT132 12/4	–	–	–	504466
10 a	8	Brake coil	–	MGN CT132	–	–	–	504033
10 a	10	Brake fan	–	BR FAN CT132	–	–	–	504045
10 a		Rectifier	–	ABR 2600	–	–	–	516092
10 a	6	Cover	–	COV CT132	–	–	–	505873
10 a	1-7	MT313, MT316	2/1, 4/1	MB132M-12/4 A1	2.3/7	14.7/17.5	440/1440	
10 a	1-3	Brake set	–	BR SET FDB 20	–	–	–	504207
10 a	2	Brake disc	–	BR DISC FDB 20	–	–	–	504225
10 a		Rectifier	–	PMG 500 S	–	–	–	806571
10 a	6	Cover	–	COV MB 132	–	–	–	
10 a	1-7	MT520, MT525	2/1, 4/1	MB160LB-4/12 A2	11.8/3.9	29.7/29	1465/465	505641
10 a	1-3	Brake set	–	BR SET MB160 LB FDB 23	–	–	–	504215
10 a	2	Brake disc	–	BR DISC FDB 23	–	–	–	504596
10 a		Rectifier	–	PMG 500 - S	–	–	–	806571
10 a	6	Cover	–	COV MB 160	–	–	–	
10 a	1-7	MT520, MT525	2/1, 4/1	CT 160L-12/4 KF8 290 TP 380 - 400V	4/12	19/30	480/1480	520108
10 a	1-3	Brake set	–	BR SET CT160 12/4 KF8	–	–	–	516046
10 a	2	Brake disc	–	BR DISC KF8	–	–	–	505855
10 a		Rectifier	–	ABR 2600	–	–	–	516092
10 a	6	Cover	–	COV CT160	–	–	–	505874

Table 10.3

Lifting Motor (Cylindrical / Single Speed), 380–400 V, 50Hz
Lifting Speed – V1

Fig.	Pos.	Type	Reeving	Name / Type	P, kW	I, A	Speed rPM	Catalog №
10 a	6-11	MT304, MT305, MT306, MT308	2/1, 4/1	CT 100LA-4 BR11 240 TP1 380–400 V	2.5	5.4	1410	809176
10 a	8-10	Brake set	–	BR SET CT100 - 4				504545
10 a	8	Brake coil	–	MGN CT100				516004
10 a	10	Brake fan	–	BR FAN CT100				504463
10 a		Rectifier	–	ABR 1600				516091
10 a	6	Cover	–	COV CT100				505370
10 a	6-11	MT310, MT312	2/1, 4/1	CT 112M-4 BR11-240 TP1 380–400 V	4	9.1	1420	810307
10 a	8-10	Brake set	–	BR SET CT112 4				810969
10 a	8	Brake coil	–	MGN CT112				501206
10 a	10	Brake fan	–	BR FAN CT112				504464
10 a		Rectifier	–	ABR 1600				516091
10 a	6	Cover	–	COV CT112				505371
10 a	6-11	MT313, MT316	2/1, 4/1	CT 132S-4 BR 240-5,5 TP1 380–400 V	5	11.5	1440	505216
10 a	8-10	Brake set	–	BR SET CT132 4				505546
10 a	8	Brake coil	–	MGN CT132				504033
10 a	10	Brake fan	–	BR FAN CT132				504045
10 a		Rectifier	–	ABR 1600				516091
10 a	6	Cover	–	COV CT132				505873
10 a	1-7	MT520, MT525	2/1, 4/1	MT 160MB-4 FDB20 TP A2 380–400 V	8	16.8	1430	806516
10 a	1-3	Brake set		BR SET MB160 MB FDB 20				504207
10 a	2	Brake disc		BR DISC FDB 20				504225
10 a		Rectifier		PMG 500 - S				806571
10 a	6	Cover		COV MB 160				
10 a	1-7	MT520, MT525	2/1, 4/1	CT 132M-4 KF7 290 TP 380 - 400V	8.5	17.7	1445	505710
10 a	1-3	Brake set	–	BR SET				
10 a	2	Brake disc	–	BR DISC				
10 a		Rectifier	–	ABR 1600				516091
10 a	6	Cover	–	COV				
10 a	1-7	MT520, MT525	2/1, 4/1	DM13-55-4 OBE-290Th	8	18	1440	515585
10 a	1-3	Brake set		BRSET DM 1355-4				516086
10 a	2	Brake disc		BR DISC DM 1355-4				516087
10 a		Rectifier		PMG 500 - S				806571
10 a	6	Cover		COV DM 1355-4				516088

Cylindrical Motor

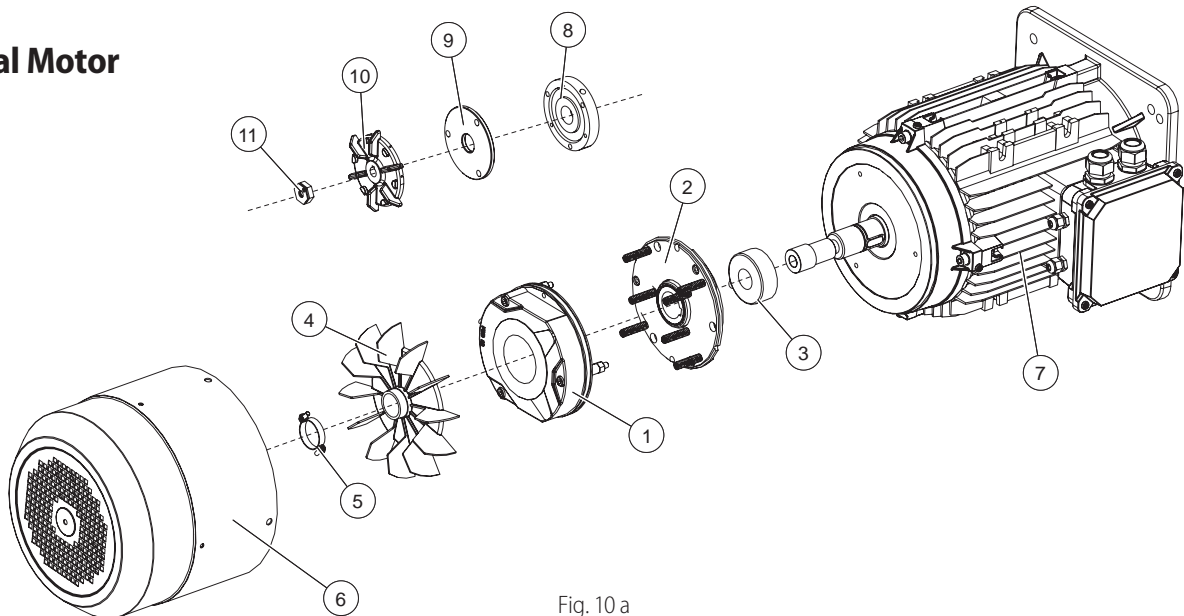

Fig. 10 a

Table 10.4

Lifting Motor (Cylindrical / Single Speed), 380–400 V, 50Hz

Lifting Speed – V2

Fig.	Pos.	Type	Reeving	Name / Type	P, kW	I, A	Speed rPM	Catalog №
10 a	6-11	MT304, MT305, MT306	2/1, 4/1	CT 100LA-4 BR11 240 TP1 380–400 V	2.5	5.4	1410	809176
10 a	8-10	Brake set	–	BR SER CT100 4				504545
10 a	8	Brake coil	–	MGN CT100				516004
10 a	10	Brake fan	–	BR FAN CT100				504463
10 a		Rectifier	–	ABR 1600				516091
10 a	6	Cover	–	COV CT100				505370
10 a	6-11	MT308	2/1, 4/1	CT 112M-4 BR11-240 TP1 380–400 V	4	9.1	1420	810307
10 a	8-10	Brake set	–	BR SET CT112 4				810969
10 a	8	Brake coil	–	MGN CT112				501206
10 a	10	Brake fan	–	BR FAN CT112				504464
10 a		Rectifier	–	ABR 1600				516091
10 a	6	Cover	–	COV CT112				505371
10 a	6-11	MT310, MT312	2/1, 4/1	CT 132S-4 BR 240-6 TP1 380-400V	6	11.7	1440	815636
10 a	8-10	Brake set	–	BR SET CT132 4				505546
10 a	8	Brake coil	–	MGN CT132				504033
10 a	10	Brake fan	–	BR FAN CT132				504045
10 a		Rectifier	–	ABR 1600				516091
10 a	6	Cover	–	COV CT132				505873
10 a	6-11	MT313, MT316	2/1, 4/1	CT 132M-4 KF7 240TP1 380–400 V	8.5	17.7	1445	505710
10 a	8-10	Brake set		BR SET CT132 KF7				
10 a	2	Brake disc		BR DISC KF7				505854
10 a		Rectifier		ABR 1600				516091
10 a	6	Cover		COV CT132				505873
10 a	1-7	MT520, MT525	2/1, 4/1	MT 160LB-4 A2 TP FL290 380–400 V	12	24	1425	814295
10 a	1-3	Brake set	–	BR SET MB160 LB FDB 23				504215
10 a	2	Brake disc	–	BR DISC FDB 23				504596
10 a		Rectifier	–	PMG 500 - S				806571
10 a	6	Cover	–	COV MT 160				
10 a	1-7	MT520, MT525	2/1, 4/1	CT 160M-4 KF8 290 TP1 380 - 400V	12	25	1440	815748
10 a	1-3	Brake set	–	BR SET KF8				
10 a	2	Brake disc	–	BR DISC KF8				505855
10 a		Rectifier	–	ABR 1600				516091
10 a	6	Cover	–	COV CT160				505874

Table 10.5

Lifting Motor (Cylindrical / Double Speed), 380–400 V, 50Hz

Lifting Speed – V2

Fig.	Pos.	Type	Reeving	Name / Type	P, kW	I, A	Speed rPM	Catalog №
10 a	1-7	MTL312, MTL316	2/1	CT 160M-12/4 B5 S340 KF7 TP 380 - 400V	8.5/2.7	16/15	1450/470	815771
10 a	1-3	Brake set		BR SET KF7 12/4				516096
10 a	2	Brake disc		BR DISC KF7				505854
10 a		Rectifier		ABR 2600				516092
10 a	6	Cover		COV CT160				505874
10 a	1-7	MTL525	2/1	CT 160L-12/4 KF8 410 TP 380 - 400V				505709
10 a	1-3	Brake set	–	BR SET KF8				
10 a	2	Brake disc	–	BR DISC KF8				505855
10 a		Rectifier	–	ABR 2600				516092
10 a	6	Cover	–	COV CT160				505874

Table 10.6

Lifting Motor (Conical/ Double Speed), 380–400 V, 50Hz

Lifting Speed – V1

Fig.	Pos.	Type	Reeving	Name / Type	P, kW	I, A	Speed rPM	Catalog №
10 b	1-10	MT305, MT308, MT310, MT312	2/1, 4/1	KE 2011M 12/4 380 - 400V	1/3	9/9	420/1400	505640
10 b	3	Brake fan	2/1, 4/1	BR FAN K 2011 12/4			–	
10 b	4	Rotor	2/1, 4/1	ROT KE 2011 12/4	–	–	–	
10 b	2	Fan housing	2/1, 4/1	KG 2011			–	430150
10 b	1	Grid	2/1, 4/1	K 2011			–	
10 b	1-10	MT316	2/1, 4/1	KE 2114M-12/4 380 - 400V	1.5/4.5	11/11.5	420/1400	505126
10 b	3	Brake fan	2/1, 4/1	BR FAN K 2114 12/4			–	
10 b	4	Rotor	2/1, 4/1	ROT KE 2114 12/4			–	
10 b	2	Fan housing	2/1, 4/1	K 2114			–	
10 b	1	Grid	2/1, 4/1	K 2114			–	
10 b	1-10	MT520, MT525	2/1, 4/1	KE 2714M-24/4 TP1 380 - 400V	1.3/8	12/16	200/1400	808766
10 b	3	Brake fan	2/1, 4/1	BR FAN K 2714M - 24/4			–	504409
10 b	4	Rotor	2/1, 4/1	ROT KE 2714 M 24/4			–	
10 b	2	Fan housing	2/1, 4/1	KG 2714 - 4			–	345084
10 b	1	Grid	2/1, 4/1	K 2714M 24/4			–	806653

Table 10.7

Lifting Motor (Conical / Single Speed), 380–400 V, 50Hz
Lifting Speed – V1

Fig.	Pos.	Type	Reeving	Name / Type	P, kW	I, A	Speed rPM	Catalog №
10 b	1-10	MT305, MT308	2/1, 4/1	KE 1608 M4 Tp1	2.3	6		
10 b	3	Brake fan	–	BR FAN KG 1608 6				345045
10 b	4	Rotor		ROT KE 1608 4				
10 b	2	Fan housing	–	KG 1608 4				505699
10 b	1	Grid	–	KG 1608	–	–	–	280001
10 b	1-10	MT310, MT312	2/1, 4/1	KE 2008 M4 Tp1	4.5	12	1400	
10 b	3	Brake fan	–	BR FAN KG 2008 6				227357
10 b	4	Rotor		ROT KE 2008 M4				
10 b	2	Fan housing	–	KG 2008 - 4				505700
10 b	1	Grid	–	KG 2008				430157
10 b	1-10	MT316	2/1, 4/1	KE 2011 M4 TP1 380V 50Hz	5	11	1400	806609
10 b	3	Brake fan	–	BR FAN KG 2011 6				280119
10 b	4	Rotor		ROT KE 2011 M4				
10 b	2	Fan housing	–	KG 2011				430150
10 b	1	Grid	–	KG 2011 4				
10 b	1-10	MT520, MT525	2/1, 4/1	K 2012 M4 TP1 380–400 V 50Hz	7.5	17	1380	806541
10 b	3	Brake fan		BR FAN K 2012 4				
10 b	4	Rotor		ROT KE 2012 M4				
10 b	2	Fan housing		K 2012 4				
10 b	1	Grid		K 2012 4				

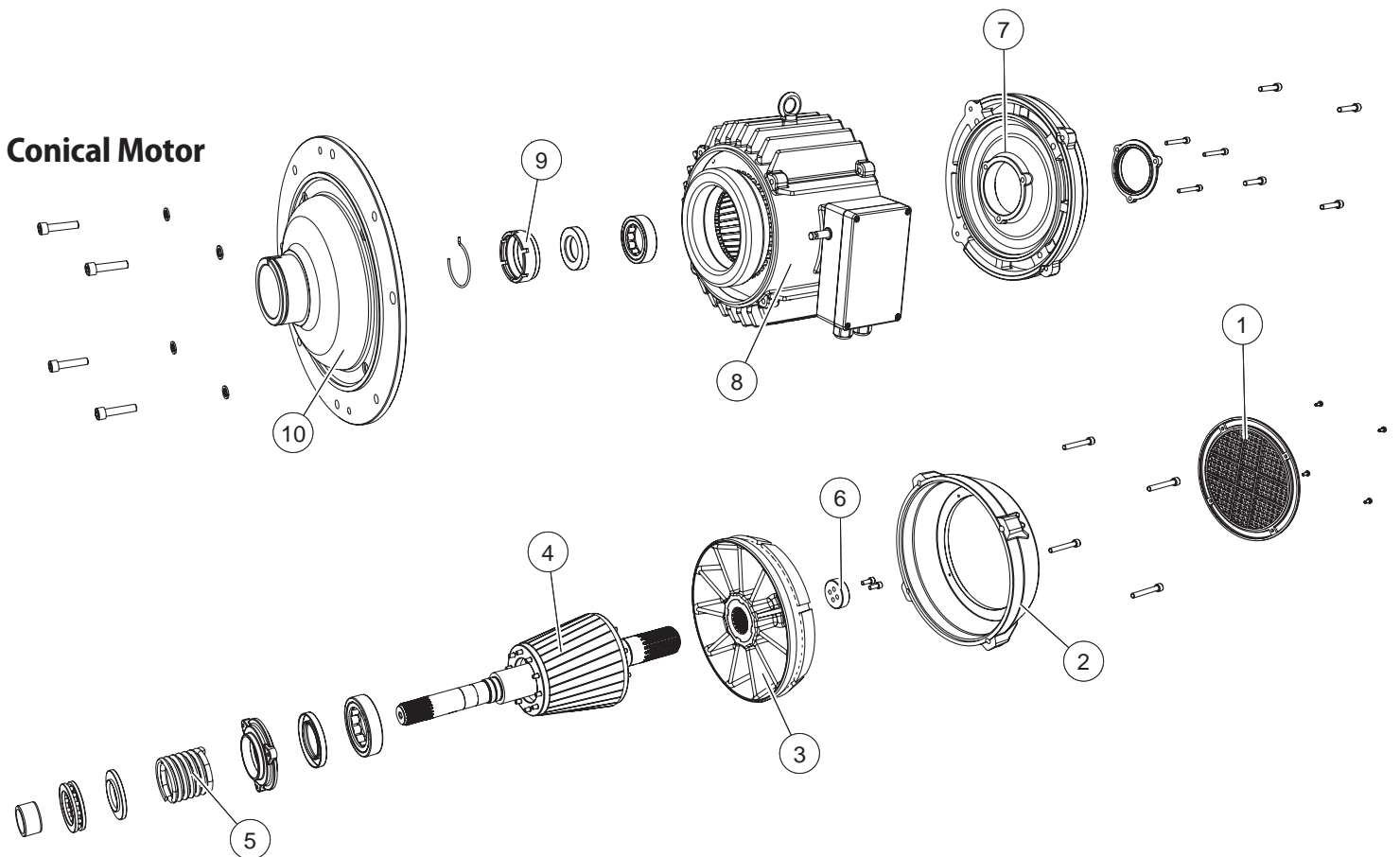

Fig. 10 b

Table 10.8

Lifting Motor (Conical / Single Speed), 380–400 V, 50Hz

Lifting Speed – V2

Fig.	Pos.	Type	Reeving	Name / Type	P, kW	I, A	Speed rPM	Catalog №
10 b	1-10	MT305	2/1, 4/1	KE 1608 M4 Tp1	2.3	6	1300	
10 b	3	Brake fan	–	BR FAN KG 1608 6				345045
10 b	4	Rotor		ROT KE 1608 4				
10 b	2	Fan housing	–	KG 1608 4				505699
10 b	1	Grid	–	KG 1608	–	–	–	280001
10 b	1-10	MT308	2/1, 4/1	KE 2008 M4 Tp1	4.5	12	1400	
10 b	3	Brake fan	–	BR FAN KG 2008 6				227357
10 b	4	Rotor		ROT K 2008 M4				
10 b	2	Fan housing	–	KG 2008 - 4				505700
10 b	1	Grid	–	KG 2008				430157
10 b	1-10	MT310, MT312	2/1, 4/1	KE 2011 M4 Tp1	5	11.2	1400	806609
10 b	3	Brake fan	–	BR FAN KG 2011 6				280119
10 b	4	Rotor		ROT KE 2011 M4				
10 b	2	Fan housing	–	KG 2011				430150
10 b	1	Grid	–	K 2011				
10 b	1-10	MT520, MT525	2/1, 4/1	K 2714 M-4 TP1 380–400 V 50Hz	12	28	1430	812707
10 b	3	Brake fan	–	BR FAN KG 2714 6				345301
10 b	4	Rotor		ROT KE 2714 M4				
10 b	2	Fan housing	–	KG 2714 - 4				345084
10 b	1	Grid	–	KG 2714 6				345305

Table 10.9

Lifting Motor (Conical/ Double Speed), 380–400 V, 50Hz

Lifting Speed – V2

Fig.	Pos.	Type	Reeving	Name / Type	P, kW	I, A	Speed rPM	Catalog №
10 b	1-10	MT305, MT308	2/1, 4/1	KE 2011M 12/4 380 - 400V	1/3	9/9	1400/420	505640
10 b	3	Brake fan	–	BR FAN K 2011 12/4				
10 b	4	Rotor		ROT KE 2011 M 12/4				
10 b	2	Fan housing	–	KG 2011				430150
10 b	1	Grid	–	K 2011 12/4				
10 b	1-10	MT310, MT312	2/1, 4/1	KE 2612M-24/4 380 - 400V	1/6	7/13.5	1400/210	806551
10 b	3	Brake fan	–	BR FAN KG 2612 24/4				345094
10 b	4	Rotor		ROT KE 2612 24/4				
10 b	2	Fan housing	–	KG1 2612				345104
10 b	1	Grid	–	KG 2612				504302
10 b	1-10	MT316	2/1, 4/1	KE 2612M-24/4 Tp1	1/6	7/13.5	210/1400	808765
10 b	3	Brake fan	–	BR FAN 2612 24/4				505219
10 b	4	Rotor		ROT KE 2612 M - 24/4				
10 b	2	Fan housing	–	KG1 2612 - 24/6				345104
10 b	1	Grid	–	K 2612M - 24/4				505219
10 b	1-10	MT520, MT525	2/1, 4/1	KE 3317M-24/4 TP1 380–400 V	12.5/1.7	23/15	1430/200	505801
10 b	3	Brake fan	–	BR FAN KG 3317 24/4				345097
10 b	4	Rotor		ROT KE 3314M 24/4				
10 b	2	Fan housing	–	KG1 3317				345106
10 b	1	Grid	–	KG 3317				505788

Table 10.10

Travel Motor for Trolley Type MB (Double Speed), 380–400 V, 50Hz

Normal Headroom / Lifting height H2-H3

Fig.	Pos.	Type	Reeving	Name / Type	P, kW	I, A	Speed rPM	Catalog №
10 c	1-6	MT304, MT305, MT306, MT308, MT310, MT312	2/1, 4/1	T80B-12/4R BR11 B5 42 380–400 V	0.12/0.37	1.9/1.9	450/1440	504532
10 c	1-3	Brake set	–	BR SET T80 12/4				505274
10 c	1	Brake coil	–	MGN T80				504234
10 c	3	Brake fan	–	BR FAN T80				806604
10 c		Rectifier	–	PBR 2100				602025
10 c	5	Cover	–	COV T80				
10 c	1-6	MT313, MT316	2/1	T80B-12/4R BR11 B5 42 380–400 V	0.12/0.37	1.9/1.9	450/1440	504532
10 c	1-3	Brake set	–	BR SET T80 12/4				505274
10 c	1	Brake coil	–	MGN T80				504234
10 c	3	Brake fan	–	BR FAN T80				806604
10 c		Rectifier	–	PBR 2100				602025
10 c	5	Cover	–	COV T80				
10 c	1-6	MT313, MT316	4/1	T90S-12/4R BR11 42 380–400 V	0.18/0.25	2/1.71	450/1440	504530
10 c	1-3	Brake set	–	BR SET T90 12/4				504542
10 c	1	Brake coil	–	MGN T90				504233
10 c	3	Brake fan	–	BR FAN T90				577840
10 c		Rectifier	–	PBR 2100				602025
10 c	5	Cover	–	COV T90				
10 c	1-6	MT520, MT525	2/1	T80B-12/4R BR11 B5 42, 380–400 V	0.12/0.37	1.9/1.9	450/1440	504532
10 c	1-3	Brake set	–	BR SET T80 12/4				505274
10 c	1	Brake coil	–	MGN T80				504234
10 c	3	Brake fan	–	BR FAN T80				806604
10 c		Rectifier	–	PBR 2100				602025
10 c	5	Cover	–	COV T80				
10 c	1-6	MT520, MT525	4/1	T90S-12/4R BR11 42, 380–400 V	0.18/0.25	2/1.71	450/1440	504530
10 c	1-3	Brake set	–	BR SET T90 12/4				504542
10 c	1	Brake coil	–	MGN T90				504233
10 c	3	Brake fan	–	BR FAN T90				577840
10 c		Rectifier	–	PBR 2100				602025
10 c	5	Cover	–	COV T90				

Таблица 10.11

Travel Motor for Trolley Type GB (Double speed), 380–400 V, 50Hz

Normal head room / Liftin height H0-H1

Fig.	Pos.	Type	Reeving	Name / Type	P, kW	I, A	Speed rPM	Catalog №
10 c	1-6	MT304, MT305	2/1	KT 80A-12/4 BR11-35 380–400V	0.08/0.25	1.2/1.3	450/1440	503525
10 c	1-3	Brake set	–	BR SET KT80 12/4				516009
10 c	1	Brake coil	–	MGN KT80				501397
10 c	3	Brake fan	–	BR FAN KT80				505330
10 c		Rectifier	–	PBR 2100				602025
10 c	5	Cover	–	COV KT80				

Continued on next page >

Таблица 10.11

Travel Motor for Trolley Type GB (Double speed), 380–400 V, 50Hz

Normal head room / Liftin height H0-H1

Fig.	Pos.	Type	Reeving	Name / Type	P, kW	I, A	Speed rPM	Catalog №
10 c	1-6	MT304, MT305	4/1	KT 80B-12/4 BR11-35 380-400V	0.12/0.37	1.5/1.8	450/1440	503820
10 c	1-3	Brake set	–	BR SET KT80				516009
10 c	1	Brake coil	–	MGN KT80				501397
10 c	3	Brake fan	–	BR FAN KT80				505330
10 c		Rectifier	–	PBR 1100				602034
10 c	5	Cover	–	COV KT80				
10 c	1-6	MT306, MT308, MT310, MT312, MT313, MT316	2/1, 4/1	KT 80B-12/4 BR11-35 380-400V	0.12/0.37	1.5/1.8	450/1440	503820
10 c	1-3	Brake set	–	BR SET KT80				516009
10 c	1	Brake coil	–	MGN KT 80				501397
10 c	3	Brake fan	–	BR FAN KT 80				505330
10 c		Rectifier	–	PBR 1100				602034
10 c	5	Cover	–	COV KT80				
10 c	1-6	MT520, MT525	2/1	KT 80B-12/4 BR11-35 380-400V	0.12/0.37	1.5/1.8	450/1440	503820
10 c	1-3	Brake set	–	BR SET KT80				516009
10 c	1	Brake coil	–	MGN KT80				501397
10 c	3	Brake fan	–	BR FAN KT80				505330
10 c		Rectifier	–	PBR 1100				602034
10 c	5	Cover	–	COV KT80				

Table 10.12

Travel Motor for Trolley Type GB (Single Speed), 380–400 V, 50Hz

Normal Headroom / Lifting height H0-H1

Fig.	Pos.	Type	Reeving	Name / Type	P, kW	I, A	Speed rPM	Catalog №
10 c	1-6	MT304, MT305, MT306, MT308	2/1	KT 71B-6 BR11-35 T11, 380–400 V	0.25	0.9	910	808126
10 c	1-3	Brake set	–	BR SET KT71 6				
10 c	1	Brake coil	–	MGN KT71 6				
10 c	3	Brake fan	–	BR FAN KT71				806603
10 c		Rectifier	–	PBR 1100				602034
10 c	5	Cover	–	COV KT71				505892
10 c	1-6	MT304, MT305	4/1	KT 71B-6 BR11-35 T11, 380–400 V	0.25	0.9	910	808126
10 c	1-3	Brake set	–	BR SET KT71 6				
10 c	1	Brake coil	–	MGN KT71 6				
10 c	3	Brake fan	–	BR FAN KT71				806603
10 c		Rectifier	–	PBR 1100				602034
10 c	5	Cover	–	COV KT71				505892
10 c	1-6	MT306, MT308	4/1	KT 80A-6 BR11-35, 380–400 V	0.37	1.45	905	504830
10 c	1-3	Brake set	–	BR SET KT80 6				505924
10 c	1	Brake coil	–	MGN KT80				501397
10 c	3	Brake fan	–	BR FAN KT80				806604
10 c		Rectifier	–	PBR 1100				602034
10 c	5	Cover	–	COV KT80				

Table 10.12

Travel Motor for Trolley Type GB (Single Speed), 380–400 V, 50Hz

Normal Headroom / Lifting height H0-H1

Fig.	Pos.	Type	Reeving	Name / Type	P, kW	I, A	Speed rPM	Catalog №
10 c	1-6	MT310, MT312, MT313, MT316	2/1	KT 80A-6 BR11-35, 380–400 V	0.37	1.45	905	504830
10 c	1-3	Brake set		BR SET KT80 6				505924
10 c	1	Brake coil		MGN KT80				501397
10 c	3	Brake fan		BR FAN KT80				806604
10 c		Rectifier		PBR 1100				602034
10 c	5	Cover		COV KT80				
10 c	1-6	MT310, MT312	4/1	KT 80A-6 BR11-35, 380–400 V	0.37	1.45	905	504830
10 c	1-3	Brake set		BR SET KT80 6				505924
10 c	1	Brake coil		MGN KT80				501397
10 c	3	Brake fan		BR FAN KT80				806604
10 c		Rectifier		PBR 1100				602034
10 c	5	Cover		COV KT80				
10 c	1-6	MT313, MT316	4/1	KT 80B-6 BR11 35, 380–400 V	0.75	2.3	1400	806600
10 c	1-3	Brake set		BR SET KT80 6				505924
10 c	1	Brake coil		MGN KT80				501397
10 c	3	Brake fan		BR FAN KT80				806604
10 c		Rectifier		PBR 1100				602034
10 c	5	Cover		COV KT80				
10 c	1-6	MT520, MT525	2/1	KT 80B-6 BR11 35, 380–400 V	0.75	2.3	1400	806600
10 c	1-3	Brake set		BR SET KT80 6				505924
10 c	1	Brake coil		MGN KT80				501397
10 c	3	Brake fan		BR FAN KT80				806604
10 c		Rectifier		PBR 1100				602034
10 c	5	Cover		COV KT80				

Table 10.13

Travel Motor for Trolley Type KM (Double Speed), 380–400 V, 50Hz

Normal Headroom / Lifting height H2-H3

Fig.	Pos.	Type	Reeving	Name / Type	P, kW	I, A	Speed rPM	Catalog №
10 c	1-6	MT305, MT308, MT312, MT316	2/1	KT 80A–12/4 84, 380–400 V	0.08/0.25	1.4/1.4	440/1450	515506
10 c	1-3	Brake set	–	BR SET KT80 12/4				516009
10 c	1	Brake coil	–	MGN KT80				501397
10 c	3	Brake fan	–	BR FAN KT80				806604
10 c		Rectifier	–	PBR 2100				602025
10 c	5	Cover	–	COV KT 80				
10 c	1-6	MT316	4/1	KT 80A–12/4 84, 380–400V	0.08/0.25	1.4/1.4	440/1450	515506
10 c	1-3	Brake set	–	BR SET KT80 12/4				516009
10 c	1	Brake coil	–	MGN KT80				501397
10 c	3	Brake fan	–	BR FAN KT80				806604
10 c		Rectifier	–	PBR 2100				602025
10 c	5	Cover	–	COV KT 80				
10 c	1-6	MT525	2/1	KT 80B–12/4 84, 380–400V	0.12/0.37	1.9/1.9	450/1440	515505
10 c	1-3	Brake set	–	BR SET KT80 12/4				516009
10 c	1	Brake coil	–	MGN KT80				501397
10 c	3	Brake fan	–	BR FAN KT80				806604
10 c		Rectifier	–	PBR 2100				602025
10 c	5	Cover	–	COV KT 80				
10 c	1-6	MT525	4/1	KT 90S–12/4 84, 380–400V				515565
10 c	1-3	Brake set	–	BR SET T90S 12/4				504542
10 c	1	Brake coil	–	MGN T90 S				
10 c	3	Brake fan	–	BR FAN T90 S				
10 c		Rectifier	–	PBR 2100				602025
10 c	5	Cover	–	COV T90 S				

Table 10.14

Travel Motor (Double Speed), 380–400 V, 50Hz
Low Headroom

Fig.	Pos.	Type	Reeving	Name / Type	P, kW	I, A	Speed rPM	Catalog №
10 c	1-6	MT304, MT305, MT306, MT308	2/1, 4/1	KT 71B–8/2 BR11, 380–400 V	0.06/0.24	0.75/0.76	710/2830	582282
10 c	1-3	Brake set	–	BR SET KT71 8/2				806601
10 c	1	Brake coil	–	MGN KT 71				
10 c	3	Brake fan	–	BR FAN KT71				806603
10 c		Rectifier	–	PBR 2100				602025
10 c	5	Cover	–	COV KT71				505892
10 c	1-6	MT310, MT312, MT313, MT316	2/1	KT 71B–8/2 BR11, 380–400 V	0.06/0.24	0.75/0.76	710/2830	582282
10 c	1-3	Brake set	–	BR SET KT71 8/2				806601
10 c	1	Brake coil	–	MGN KT 71				
10 c	3	Brake fan	–	BR FAN KT71				806603
10 c		Rectifier	–	PBR 2100				602025
10 c	5	Cover	–	COV KT71				505892
10 c	1-6	MT310, MT312, MT313, MT316	4/1	KT 80B–8/2 BR11–53, 380–400 V	0.13/0.55	1.4/1.7	720/2880	806509
10 c	1-3	Brake set	–	BR SET KT80 8/2				516009
10 c	1	Brake coil	–	MGN KT80				501397
10 c	3	Brake fan	–	BR FAN KT80				806604
10 c		Rectifier	–	PBR 2100				602025
10 c	5	Cover	–	COV KT 80				
10 c	1-6	MT520, MT525	2/1, 4/1	KT 80B–8/2 BR11–53, 380–400 V	0.13/0.55	1.4/1.7	720/2880	806509
10 c	1-3	Brake set	–	BR SET KT80 8/2				516009
10 c	1	Brake coil	–	MGN KT80				501397
10 c	3	Brake fan	–	BR FAN KT80				806604
10 c		Rectifier	–	PBR 2100				602025
10 c	5	Cover	–	COV KT 80				

Travel Motors for Standard Speed
V=20/5 m/min and V=20 m/min

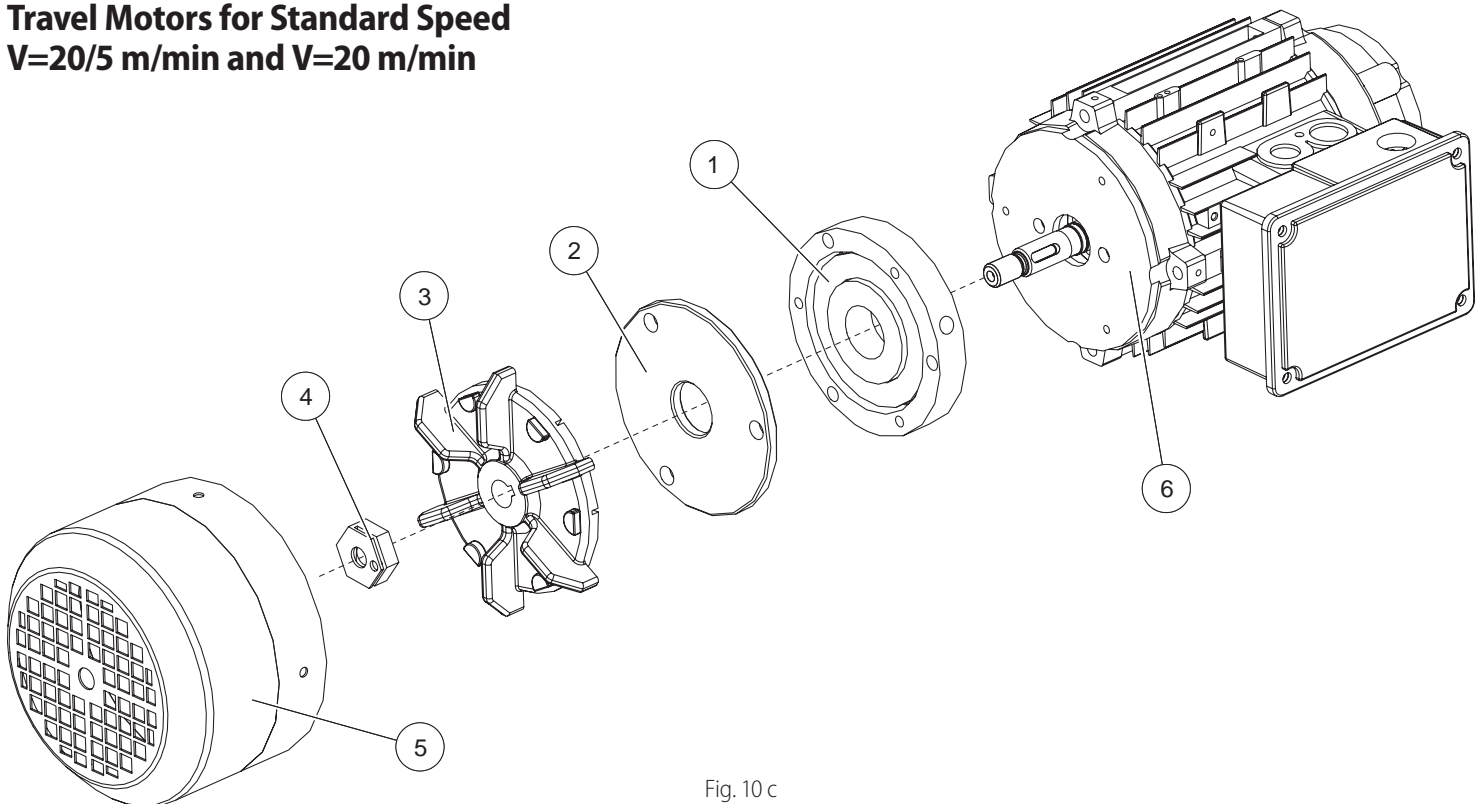

Fig. 10 c

Table 10.15

Travel Motor (Single Speed), 380–400 V, 50Hz

Low Headroom

Fig.	Pos.	Type	Reeving	Name / Type	P, kW	I, A	Speed rPM	Catalog №
10 c	1-6	MT304, MT305, MT306, MT308	2/1, 4/1	KT 63B–2 BR1I, 380–400 V	0,25	0,84	2770	581542
10 c	1-3	Brake set	–	BR SET KT63 2				
10 c	1	Brake coil	–	MGN KT63				505417
10 c	3	Brake fan	–	BR FAN KT63				806602
10 c		Rectifier	–	PBR 1100				602034
10 c	5	Cover	–	COV KT 63				
10 c	1-6	MT310, MT312, MT313, MT316	2/1	KT 63B–2 BR1I, 380–400 V	0,25	0,84	2770	581542
10 c	1-3	Brake set	–	BR SET KT63 2				
10 c	1	Brake coil	–	MGN KT63				505417
10 c	3	Brake fan	–	BR FAN KT63				806602
10 c		Rectifier	–	PBR 1100				602034
10 c	5	Cover	–	COV KT 63				
10 c	1-6	MT310, MT312, MT313, MT316	4/1	KT 71B–2 BR1I–53, 380–400 V	0,55	1,4	2790	806695
10 c	1-3	Brake set	–	BR SET KT71 2				
10 c	1	Brake coil	–	MGN K71				
10 c	3	Brake fan	–	BR FAN KT71				806603
10 c		Rectifier	–	PBR 1100				602034
10 c	5	Cover	–	COV KT71				505892
10 c	1-6	MT520, MT525	2/1, 4/1	KT 71B–2 BR1I–53, 380–400 V	0,55	1,4	2790	806695
10 c	1-3	Brake set	–	BR SET KT71 2				
10 c	1	Brake coil	–	MGN K71				
10 c	3	Brake fan	–	BR FAN KT71				806603
10 c		Rectifier	–	PBR 1100				602034
10 c	5	Cover	–	COV KT71				505892

Table 10.16

Travel Motor for Trolley Type MB (Single Speed), 380–400 V, 50Hz

Normal Headroom

Fig.	Pos.	Type	Reeving	Name / Type	P, kW	I, A	Speed rPM	Catalog №
10 c	1-6	MTL312, MTL316, MTL525	2/1	T80A-4 BR II 42 380 - 400V	0,55	1,62	1400	504531
10 c	1-3	Brake set	–	BR SET T80 4				505273
10 c	1	Brake coil	–	MGN T80				504234
10 c	3	Brake fan	–	BR FAN T80				
10 c		Rectifier	–	PBR 1100				602034
10 c	5	Cover	–	COV T80				812604

Table 10.17

Travel Motor for Trolley Type MB (Double Speed), 380–400 V, 50Hz

Normal Headroom

Fig.	Pos.	Type	Reeving	Name / Type	P, kW	I, A	Speed rPM	Catalog N°
10 c	1-6	MTL312, MTL316, MTL525	2/1	T80A-12/4R BR II B5 42				815566
10 c	1-3	Brake set	–	BR SET T80 12/4				505274
10 c	1	Brake coil	–	MGN T80				504234
10 c	3	Brake fan	–	BR FAN T80				
10 c		Rectifier	–	PBR 2100				602025
10 c	5	Cover	–	COV T80				812604

Group 11 – Travel Mechanism – Normal Headroom

Table 11.1

Trolley Type KM

Reeving

2/1

4/1

Lifting height

H2, H3

Wheel diameter

ø 120 mm

ø 140 mm

Fig.	Pos.	Name	Qty	Catalog N°	
				MT 305, MT 308, MT 312, MT 316, MT 525	MT 316, MT 525
11 a	1-22	Driving trolley set	1		
11 a	1-22		1	–	–
11 a	1-5	Driving side set	1	815791	815943
11 a	1-5		1	–	–
11 a	2-4	Driving wheel set	2	815795	815945
11 a	2-4			–	–
11 a	2	Driving wheel	2	815796	815946
11 a	2			–	–
11 a	1	Driving side with axles	1	810297	810390
11 a	4	Ring*	4	809242	815075
11 a	3	Bearing*	2	505945	826412
11 a	5	Ring*	2	208714	809249
11 a		Driven side set	1	815792	815944
11 a	(Pos. 3, 4, 5, 10, 11)		1	–	–
11 a		Driven wheel set	2	815807	815944
11 a	(Pos. 3, 4, 10)		2	–	–
11 a	10	Driven wheel	2	815808	815957
11 a	10		2	–	–
11 a	11	Driving side with axles	1	810304	810397
11 a	4	Ring*	4	809242	815075
11 a	3	Bearing*	2	505945	826412

Continued on next page >

Table 11.1

Trolley Type KM		Reeving		Lifting height			
				2/1	4/1	H2, H3	
				Wheel diameter		H2, H3	
				ø 120 mm	ø 140 mm	H2, H3	
Fig.	Pos.	Name	Qty	Catalog №			
				MT 305, MT 308, MT 312, MT 316, MT 525	MT 316, MT 525		
11 a	5	Ring*	2	208714	809249		
11 a	14	Stud	1	810406	810388		
11 a	6	Bolt*	1	229169	575965		
11 a	7	Washer*	2	211974	211974		
11 a	8	Spring washer*	1	208635	208635		
11 a	9	Nut*	1	800914	800914		
11 a	15	Bush	4	810291	810386		
11 a	13	Bush	16	810292	810387		
11 a	16	Washer*	1	211978	211977		
11 a		Nut*	1	805667	–		
11 a	17	Nut*	1	–	825836		
11 a	18	Safety nut*	1	230566	–		
11 a	19	Pin*	1	–	219334		
11 a	3-19	Driven trolley set	Universal slope	1			
11 a	3-19		Zero slope	1	–	–	
11 a		Driven side set (Pos. 3, 4, 5, 10, 11)	Universal slope	2	815792	815944	
11 a			Zero slope	2	–	–	
11 a		Driven travel wheel set (Pos. 3, 4, 10)	Universal slope	4	815807	815955	
11 a			Zero slope	4	–	–	
11 a	10	Driven travel wheel	Universal slope	4	815808	815957	
11 a	10		Zero slope	4	–	–	
11 a	11	Driving side with axles		2	810304	810397	
11 a	4	Ring*	8	809242	815075		
11 a	3	Axles*	4	505945	826412		
11 a	5	Ring*	4	208714	809249		
11 a	14	Stud	1	810406	810388		
11 a	6	Bolt*	1	229169	575965		
11 a	7	Washer*	2	211974	211974		
11 a	8	Spring washer*	1	208635	208635		
11 a	9	Nut*	1	800914	800914		
11 a	15	Bush	4	810291	810386		
11 a	13	Bush	16	810292	810387		
11 a	16	Washer*	1	211978	211977		
11 a		Nut*	1	805667	–		
11 a	17	Nut*	1	–	825836		
11 a	18	Safety nut*	1	230566	–		
11 a	19	Pin*	1	–	219334		

– * For DIN or BDS designations please see page 53–54, table 12.2

– ** Trolley type KM is standard for Podem. This type of trolley is mounted on all hoists with lifting height H2 and H3 after October 2014.

Table 11.2

Motor-reducer for Trolley Type KM Speed – 20/6 m/mi n		Reeving					
		2/1		4/1			
		Lifting height					
		H2, H3					
		Wheel diameter					
		ø 120 mm		ø 140 mm			
Fig.	Pos.	Name	Qty	Catalog N°			
				MT 305, MT 308, MT 312, MT 316	MT 525	MT 316	MT 525
20-22		Motor-reducer set		810288	815941	810288	817374
	22	El. motor		515506	515505	515506	515565
11 b	21	Pinion	1	148899	148899	148899	148899
	20	Reducer		On request	On request	On request	On request

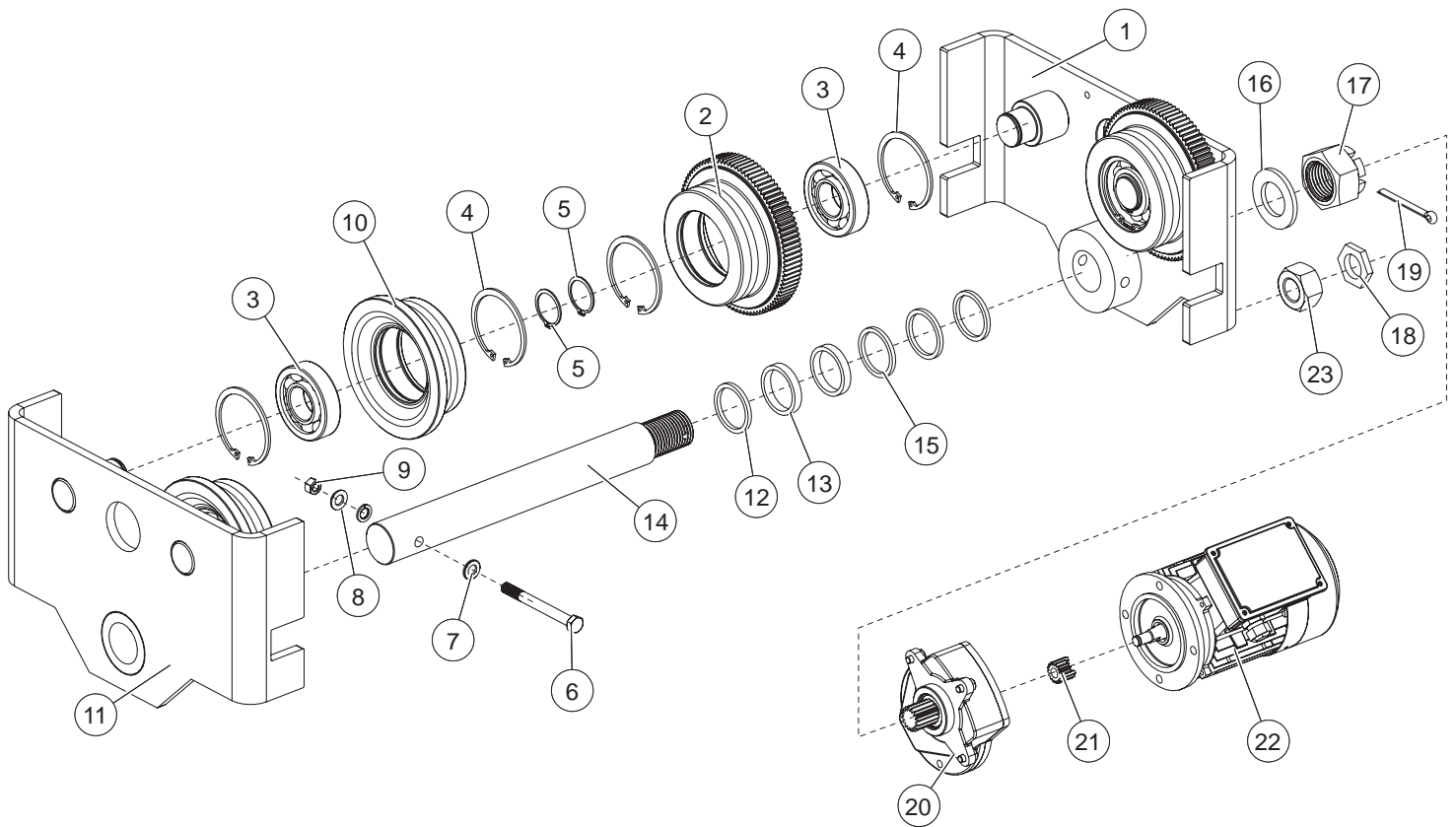

Fig. 11 a

Table 11.3

Trolley Type MB Reeving 2/1		Lifting height		Qty	Catalog Nº
		H2	H3		
Fig.	Pos.	Name	Wheel diameter		MT 305, MT 312, MT 316, MT 525
			ø 120 mm		
11 a	1-19	Driving trolley set	Universal slope	1	812539 ¹
11 a	1-19		Zero slope	1	812622 ¹
11 a	1-5	Driving side	Universal slope	1	806862
11 a	1-5		Zero slope	1	810461
11 a	2-4	Driving wheel set	Universal slope	2	
11 a	2-4		Zero slope	2	
11 a	3, 4, 5, 10, 11	Driven side	Universal slope	1	806863
11 a	3, 4, 5, 10, 11		Zero slope	1	810462
11 a	3, 4, 10	Driven wheel set	Universal slope	2	
11 a	3, 4, 10		Zero slope	2	
11 a	14	Stud for profile to 300 mm		1	809053
11 a	6	Bolt**		1	229169
11 a	7	Washer**		2	211974
11 a	8	Spring washer**		1	208635
11 a	9	Nut**		1	800914
11 a	13	Bush		6	808546
11 a	15	Bush		2	204032
11 a	12	Bush		2	831596
11 a		Washer		2	204033
11 a	16	Washer**		1	211978
11 a	17	Nut**		1	805667
11 a	18	Safety nut		1	230566
11 a		Driven trolley set	Universal slope	1	808943 ¹
11 a			Zero slope	1	808945 ¹
11 a	3, 4, 5, 10, 11	Driven side	Universal slope	2	806863
11 a	3, 4, 5, 10, 11		Zero slope	2	810462
11 a	3, 4, 10	Driven wheel set	Universal slope	4	
11 a	3, 4, 10		Zero slope	4	
11 a	14	Stud for profile to 300 mm		1	809053
11 a	6	Bolt**		1	229169
11 a	7	Washer**		2	211974
11 a	8	Spring washer**		1	208635
11 a	9	Nut**		1	800914
11 a	13	Bush		6	808546
11 a	15	Bush		2	204032
11 a	12	Bush		2	831596
11 a		Washer		2	204033
11 a	16	Washer**		1	211978
11 a	17	Nut**		1	805667
11 a		Safety nut		1	230566

– * For DIN or BDS designations please see page 53–54, table 12.2

– 1: Trolley for girder with width maximum 300 mm.

46 You can order hoist with two driving trolleys.

Table 11.4

Trolley Type GB Reeving 2/1				Lifting height		
				H0, H1		
				Wheel diameter		
Fig.	Pos.	Name	Qty	ø 100 mm	ø 125 mm	ø 160 mm
				Catalog Nº		
				MT305, MT308	MT312, MT316	MT525
11 b	1-20	Driving trolley set	Universal slope	1		
11 b	1-20		Zero slope		-	-
11 b	1-4	Driving side set	Universal slope	1	815895	504742
11 b	1-4		Zero slope		-	-
11 b	2-3	Driving wheel set	Universal slope	2		815362
11 b	2-3		Zero slope		-	-
11 b	11, 12, 20	Driven side set	Universal slope	1	815896	504741
11 b	11, 12, 20		Zero slope		-	-
11 b	12-20	Driven travel wheel set	Universal slope	2		815361
11 b	12-20		Zero slope		-	-
11 b	14	Stud for profile to 300 mm		2	192761	192767
11 b	16	Washer		30	192563	148901
11 b	22	Bush		6	192558	148902
11 b	17	Bush		4	241643	241642
11 b	18	Washer*		2	211981	211978
11 b		Nut*		2	228510	805667
11 b	19	Safety nut		2	230565	230566
11 b		Nut*		2	-	-
11 b		Pin*		2	-	-

- * For DIN or BDS designations please see page 53-54, table 12.2

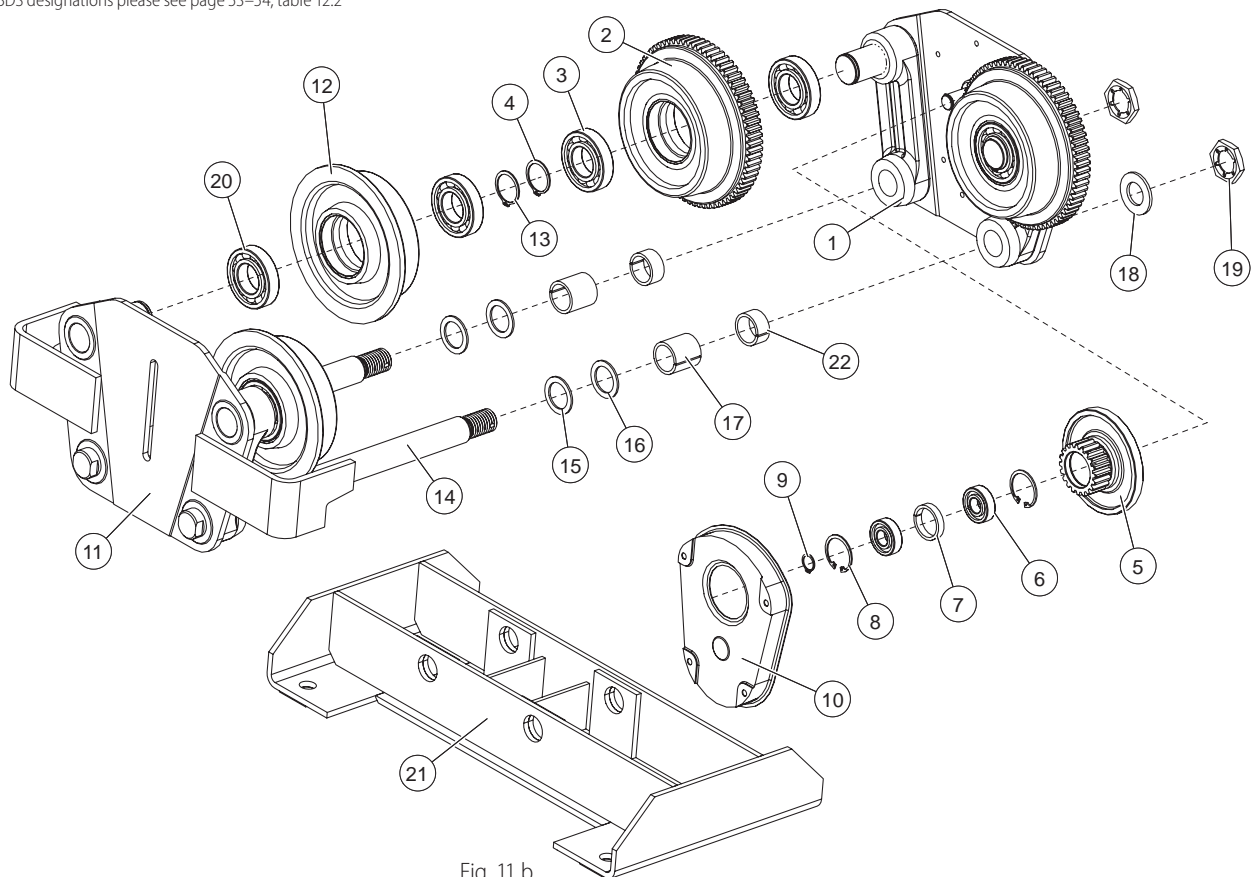

Fig. 11 b

Table 11.5

Trolley Type MB Reeving 4/1		Lifting height H2, H3							
		Wheel diameter							
				ø 120 mm	ø 140 mm	ø 140 mm	ø 140 mm	ø 140 mm	ø 140 mm
		Fig.	Pos.	Name	Qty	Catalog N°			
				MT305, MT308, MT312, MTL312, MTL316	MT316	MT316	MT525	MT525	
11 a	1-19	Driving trolley set	Universal slope		812539 ¹	812538 ¹	812638 ²	812538 ¹	813849 ⁴
11 a	1-19		Zero slope		812622	812784 ³	–	–	–
11 a	1-5	Driving side set	Universal slope	1	806862	806424	806424	806424	813847
11 a	1-5		Zero slope	1	810461	810459	–	–	–
11 a	2-4	Driving wheel set	Universal slope						
11 a	2-4		Zero slope						
11 a	3, 4, 5, 10, 11	Driven side set	Universal slope	1	806863	806423	806423	806423	813848
11 a	3, 4, 5, 10, 11		Zero slope	1	810462	810460	–	–	–
11 a	3, 4, 10	Driven wheel set	Universal slope						
11 a	3, 4, 10		Zero slope						
11 a	14	Stud for profile to 300 mm		1	809053	809054	–	809054	809054
11 a	14	Stud for profile to 400 mm		1	–	–	811781	–	–
11 a	14	Stud for profile to 500 mm		1	–	812783	–	–	–
11 a	6	Bolt**		1	229169	575965	575965	575965	575965
11 a	7	Washer**		2	211974	211974	211974	211974	211974
11 a	8	Spring washer**		1	208635	208635	208635	208635	208635
11 a	9	Nut**		1	800914	800914	800914	800914	800914
11 a		Washer AM45**		1	–	842428	842428	842428	842428
11 a	17	Nut**		1	–	825836	825836	825836	825836
11 a	19	Pin**		1	–	211989	211989	211989	211989
11 a		Spring washer**		4	–	805570	805570	805570	805570
		Nut**		4	–	580385	580385	580385	580385
	13	Bush		6	808546	–	–	–	–
	15	Bush		2	204032	–	–	–	–
	12	Bush		2	831596	–	–	–	–
		Washer		2	204033	–	–	–	–
	16	Washer**		1	211978	–	–	–	–
		Nut**		1	805667	–	–	–	–
	18	Safety nut		1	230566	–	–	–	–
11 a		Driven trolley set	Universal slope		808943 ¹	808941 ¹	812639 ²	–	–
11 a			Zero slope		808945	812785	–	–	–
11 a	3, 4, 5, 10, 11	Driven side	Universal slope	2	806863	808423	806423	–	–
11 a	3, 4, 5, 10, 11		Zero slope	2	810462	810460	–	–	–
11 a	3, 4, 10	Driven wheel set	Universal slope						
11 a	3, 4, 10		Zero slope						

Continued on next page >

Table 11.5

Trolley Type MB Reeving 4/1		Lifting height H2, H3						
		Wheel diameter						
		ø 120 mm	ø 140 mm	ø 140 mm	ø 140 mm	ø 140 mm		
Fig.	Pos.	Name	Qty	Catalog N°				
				MT305, MT308, MT312, MTL312, MTL316	MT316	MT316	MT525	MT525
11 a	14	Stud for profile to 300 mm	1	809053	809054	–	–	–
11 a	14	Stud for profile to 400 mm	1	–	–	811781	–	–
11 a	14	Stud for profile to 500 mm	1	–	812783	–	–	–
11 a	6	Bolt**	1	229169	575965	575965	–	–
11 a	7	Washer**	2	211974	211974	211974	–	–
11 a	8	Spring washer**	1	208635	208635	208635	–	–
11 a	9	Nut**	1	800914	800914	800914	–	–
11 a	13	Bush	6	808546	–	–	–	–
11 a	15	Bush	2	204032	–	–	–	–
11 a	12	Bush	2	831596	–	–	–	–
11 a		Washer	2	204033	–	–	–	–
11 a	16	Washer**	1	211978	–	–	–	–
		Nut**	1	805667	–	–	–	–
	18	Safety nut	1	230566	–	–	–	–

– * Trolley type MB is constructed with one Stud and in every one hoist with this type of trolley are mounted two pcs. trolleys

– ** For DIN or BDS designations please see page 53–54, table 12.2

– 1: Trolley for girder with width maximum 300 mm

– 2: Trolley for girder with width maximum 400 mm

– 3: Trolley for girder with width maximum 500 mm

– 4: Trolley sides are 45 mm higher than standard trolleys.

Hoist type MTS25 4/1 is with 2 driving trolleys.

Table 11.6

Trolley Type GB Reeving 4/1				Lifting height		
				H1		
				Wheel diameter		
Fig.	Pos.	Name	Qty	Catalog №		
				ø 125 mm	ø 160 mm	
				MT305, MT308	MT312	
11 b	1-20	Driving trolley set	Universal slope	813811	809545	
11 b			Zero slope	–	–	
11 b	1-4	Driving side	Universal slope	504742	811858	
11 b			Zero slope	–	–	
11 b	2,3	Driving wheel set	Universal slope	815362	815366	
11 b			Zero slope	–	–	
11 b	11,12,20	Driven side	Universal slope	504741	811859	
11 b			Zero slope	–	–	
11 b	12, 20	Driven wheel set	Universal slope	815361	815365	
11 b			Zero slope	–	–	
11 b	14	Stud for profile to 300 mm	2	192767	418340	
11 b	15	Washer*	30	148901	148986	
11 b	22	Bush	6	148902	814621	
11 b	17	Bush	2	241642	241641	
11 b	18	Washer*	2	211978	842428	
11 b		Nut*	2	805667	–	
11 b	19	Safety nut	2	230566	–	
11 b		Nut*	2	–	825836	
11 b		Pin*	2	–	211989	

– * For DIN or BDS designations please see page 53–54, table 12.2

Table 11.7

				Lifting height										
				H1	H2	H3	H1	H2	H3	H1	H2	H3		
				Catalog №										
Fig.	Pos.	Name	Qty											
				MT305			MT308			MT312, MT316			MT525	
11 b	21	Frame	1	809120	–	–	809120	–	–	809069	–	–	–	–
11 b		Traverse	2	–	–	808948	–	808948	808948	–	808922	808922	808637	808637

Table 11.8

Pinion for trolley type GB				Reeving							
				2/1			4/1				
				Lifting height							
				H0, H1			H1				
				Speed, m/min							
				20		20/6		20		20/6	
Fig.	Pos.	Name	Qty	Catalog №							
				MT 305, MT 308				MT 312, MT 316, MT525			
11 a	21	Колело зъбно пиньон	1	192553	254497	148899	254495	148899	254495	148899	254495
11 a		Пръстен осигурителен	1	225033	225033	211960	211960	211960	211960	211960	211960

Affix for speed V=12 m/min, V=15 m/min, V=12/4 m/min, V=15/5 m/min, V=20/6 m/min

The standard speed is 20 m/min for single speed and 20/6 m/min for double speed trolley.

Table 11.8

Single Speed

Fig.	Pos.	Type	Reeving	Speed (m/min)	Name	Catalog N°
		MT305, MT308	2/1	12	PK 127	
		MT305	4/1	12	PK 257	
		MT312, MT316, MT525	2/1	12	PK 257	
		MT308, MT312, MT316	4/1	12	PK 257	
		MT305, MT308	2/1	15	PK 188	
		MT305	4/1	15	PK 378	
		MT312, MT316, MT525	2/1	15	PK 378	
		MT308, MT312, MT316	4/1	15	PK 378	

Table 11.9

Double Speed

Fig.	Pos.	Type	Reeving	Speed (m/min)	Name	Catalog N°
		MT305, MT308	2/1	12/4	PK 1811	
		MT305	4/1	12/4	PK 3711	254450
		MT312, MT316, MT525	2/1	12/4	PK 3711	254450
		MT308, MT312, MT316	4/1	12/4	PK 3711	254450
		MT305, MT308	2/1	15/5	PK 1812	254458
		MT305	4/1	15/5	PK 3712	254475
		MT312, MT316, MT525	2/1	15/5	PK 3712	254475
		MT308, MT312, MT316	4/1	15/5	PK 3712	254475
		MT305, MT308	2/1	20/6,5	1813	254459
		MT305	4/1	20/6,5	3713	254452
		MT312, MT316, MT525	2/1	20/6,5	3713	254452
		MT308, MT312, MT316	4/1	20/6,5	3713	254452

Table 12.1

Fig.	Pos.	Name	Description	Indicate on the schemes	Catalog №
12	7	Contactora	LC1 D09E7 9A 48V	Q, 2K, 3K, 5K, 6K	
12	7	Contactora	LC1 D12E7 12A 48V	2K, 3K	507074
12	7	Contactora	LC1 D18E7 18A 48V	Q, 2K, 3K	504188
12	7	Contactora	LC1 D25E7 25A 48V	Q, 2K, 3K	503701
12	7	Contactora	LC1 D32E7 32A 48V	Q, 2K, 3K	584126
12	7	Contactora	LC1 D38E7 38A 48V	2K, 3K	506432
12	7	Contactora	LC1 D40E7 40A 48V	2K, 3K	503922
12	7	Contactora	LC1 D50E7 50A 48V	Q, 1K, 2K	503961
12	7	Contactora	LC1 D80E7 80A 48V	3K, 4K	503958
12	7	Contactora	LC1 D098E7 9A 48V - 4 POLES	1K, 4K	504685
12	7	Contactora	LC1 D128E7 12A 48V - 4 POLES	1K	507075
12	7	Contactora	LC1 D188E7 18A 48V - 4 POLES	1K	504189
12	7	Contactora	LC1 D258E7 25A 48V - 4 POLES	1K	503700
12	7	Contactora	LC1 D40008E7 40A 48V - 4 POLES	1K	582188
12	7	Contactora	LC1 D09D7 9A 42V	Q, 2K, 3K, 5K, 6K	503944
12	7	Contactora	LC1 D12D7 12A 42V	2K, 3K	503945
12	7	Contactora	LC1 D18D7 18A 42V	Q, 2K, 3K	503847
12	7	Contactora	LC1 D25D7 25A 42V	Q, 2K, 3K	503975
12	7	Contactora	LC1 D32D7 32A 42V	Q, 2K, 3K	503989
12	7	Contactora	LC1 D38D7 38A 42V	2K, 3K	503995
12	7	Contactora	LC1 D40D7 40A 42V	2K, 3K	503946
12	7	Contactora	LC1 D50D7 50A 42V	Q, 1K, 2K	503999
12	7	Contactora	LC1 D80D7 80A 42V	3K, 4K	584111
12	7	Contactora	LC1 D098D7 9A 42V - 4 POLES	1K, 4K	503947
12	7	Contactora	LC1 D128D7 12A 42V - 4 POLES	1K	503948
12	7	Contactora	LC1 D188D7 18A 42V - 4 POLES	1K	503990
12	7	Contactora	LC1 D258D7 25A 42V - 4 POLES	1K	503976
12	7	Contactora	LC1 D40008D7 40A 48V - 4 POLES	1K	581834
12	9	Contactora block	LADN20	3K	503707
12	9	Contactora block	LADN40	3K	503779
12	10	Contactora block	LADTO	Q	584128
12	4	Time relay	RE8RA11BTQ	1T	501440
12	2	Socket	WAGO 788-102	1P, 11K, 12K, 13K	505362
12	11	Relay	2CO 24VAC RSB2A080B7	1P, 12K, 13K	505375
12	11	Relay	2CO 48VAC RSB2A080E7	11K, 12K, 13K	505374
12		Current motor protection	GZ1M07 1,6-2,5A	F5	805691
12		Current motor protection	GZ1M08 2,5-4A	F5	805690
12		Current motor protection	GZ1M10 4-6,3A	F5	805689
12		Current motor protection	GZ1M14 6-10A	F4	805688
12		Current motor protection	GZ1M16 9-14A	F4	805745
12		Current motor protection	GZ1M20 13-18A	F4	805746
12		Current motor protection	GZ1M21 17-23A	F4	503983
12		Current motor protection	GZ1M32 25-32A	F4	805747
12		Current motor protection	GV3P50 37A-50A	F4	806725
12		Current motor protection	GV3ME80 56-80A	F4	503866

Continued on next page >

Table 12.1

Fig.	Pos.	Name	Description	Indicate on the schemes	Catalog №
12	1	Transformer	60VA 380–400-415V / 24-42-48V	T1	505480
12	1	Transformer	200VA 380–400-415V / 24-42-48V	T1	505479
		Pendant control	NUX HY-1022SD (2+STOP)		505713
		Pendant control	NUX HY-1024SBB (1+1+STOP)		505714
		Pendant control	NUX HY-1024SDD (2+2+STOP)		505715
		Pendant control	NUX HY-1026SBBB (1+1+1+STOP)		505716
		Pendant control	NUX HY-1026SDDD (2+2+2+STOP)		505717

Electrical Equipment

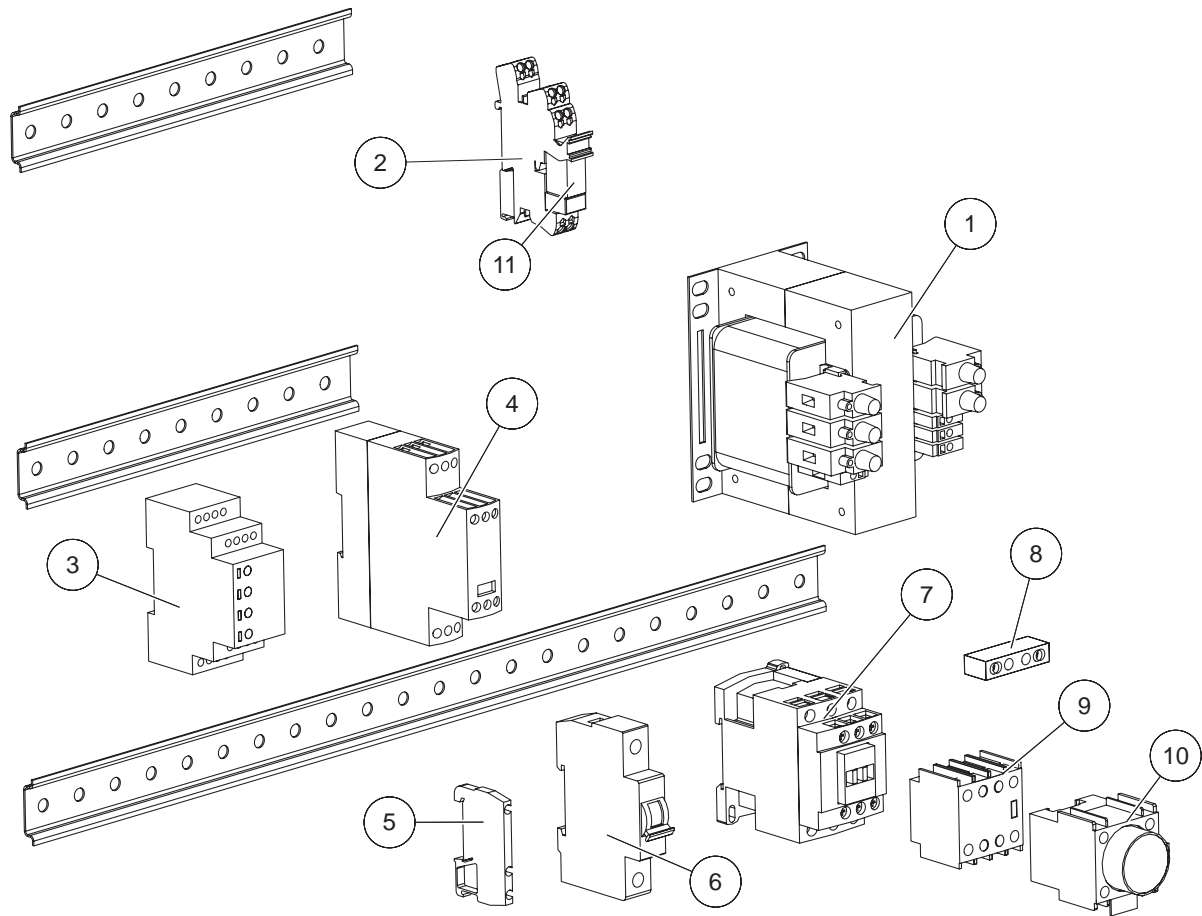

Fig. 12

DIN and BDS designations of Fasteners and Bearings

Table 12.2

Catalog №	DIN and BDS designations	Catalog №	DIN and BDS designations	Catalog №	DIN and BDS designations
205946	DIN 6004 d 20 D 42 B 12 P6	222029	DIN 933 – M6X25 – 8,8	805328	DIN 933 – M6X12 – 8,8
205981	DIN 6206 d 30 D 62 B 16 P0	224215	DIN 6209 2Z (2RS) d 45 D 85 B 19	805429	DIN 933 – M6X30 – 8,8
205993	DIN 6218 d 90 D 160 B 30 P6	225033	DIN 471 – 10x1	805542	DIN 935 – M16 – 8
206016	DIN 6210 N d 50 D 90 B 20 P6	228378	DIN 6211 2Z (2RS) d 55 D 100 B 21	805570	DIN 7980 – 8

Table 12.2

Catalog Nº	DIN and BDS designations	Catalog Nº	DIN and BDS designations		
206021	DIN 6215 d 75 D 130 B 25 P6	228510	DIN 934 – M24 – 8	805578	DIN 84 – A M8X40
206041	DIN 6210 2Z (2RS) d50 D90 B20 P6	229169	DIN 933/DIN 931 – M12X100 – 8,8	805599	DIN 7980 – 6
206047	DIN 6305 d 25 D 62 B 17 P6	250800	DIN 933 – M12X60 – 8,8	805667	DIN 934 – M30 – 8
206406	DIN 51107 d 35 D 52 B 12	251241	DIN 6205 d 25 D 52 B 15 P6	806377	DIN 1440 – 16
206407	DIN 51108 d 40 D 60 B 13	251386	DIN 912 – M10X30 – 8,8	806543	DIN 84 – A M4X45
207472	BDS 2170 77 A 52	504757	DIN 463 – 14	807570	MT 5251 00 00 06
207473	DIN 471 – 20x1,2	504900	DIN 6204 d 20 D 47 B 14 P6	808143	DIN 934 – M10 – 8
207936	DIN 912 – M6X18 – 8,8	504901	DIN 6206 d 30 D 62 B 16 P6	809007	DIN 472 – 47x1,75
208054	BDS 9954 83 130 160 15 A	504902	DIN 6208 d 40 D 80 B 18 P6	809008	DIN 471 – 42x1,75
208210	DIN 7980 – 16	504944	DIN 7985 – M4X50	809239	DIN 471 – 30x1,5
208248	DIN 7980 – 14	575763	DIN 912 – M8X90 – 8,8	809242	DIN 472 – 62x2
208482	DIN 471 – 52x2	575764	DIN 912 – M10X100 – 8,8	809248	DIN 472 – 80x2,5
208635	DIN 7980 – 12	575765	DIN 912 – M10X120 – 8,8	809249	DIN 471 – 40x1,75
208707	BDS 2170 77 A 72	576872	DIN 933/DIN 931 – M14X110 – 8,8	809892	BDS 5300 78 52 A
208708	BDS 2170 77 B 35	577625	DIN 94 – 2,5X20	809913	DIN 7985 – M4X8 – 4,8 Zn
208709	BDS 2170 77 A 110	577626	DIN 94 – 4X28	811036	DIN 472 – 52x2
208713	DIN 471 – 75x2,5	577649	BDS 2170 77 A 130	812682	DIN 463 – 12
208714	DIN 471 – 25x1,2	578435	DIN 2093 23X12,2X1,25	812750	DIN 463 – 10
208716	BDS 2170 77 B 30	578436	DIN 2093 34X16,3X2	823925	DIN 125 14
208719	BDS 2170 77 B 45	578437	DIN 2093 45X22,4X2,5	824168	DIN 94 – 4X32
208721	DIN 471 – 50x2	580385	DIN 934 – M8 – 8	824451	DIN 6312 2Z (2RS) d 60 D 130 B 31
208726	BDS 2170 77 A 47	581545	DIN 912 – M6X80 – 8,8	824894	DIN 7980 – 10
208727	BDS 2170 77 A 62	581967	DIN 6000 2Z (2RS) d 10 D 26 B 8	825051	BDS 2170 77 A 90
208734	DIN 471 – 60x2	629105	DIN 6218 N d 90 D 160 B 30 P6	825060	DIN 6212 2Z (2RS) d 60 D 110 B 22
208736	DIN 471 – 55x2	800510	DIN 51105 d 25 D 42 B 11	825382	DIN 912 – M6X16 – 8,8
208738	DIN 2170 77 A 80	800511	DIN 51106 d 30 D 47 B 11	825551	DIN 6309 2Z (2RS) d 45 D 100 B 25
208873	DIN 6207 2Z (2RS) d 35 D 72 B 17	800913	DIN 933 – M10X35 – 8,8	825569	DIN 6208 2Z (2RS) d 40 D 80 B 18
209102	BDS 9954 83 100 130 12 A	800914	DIN 934 – M12 – 8	825829	DIN 933 – M14X60 – 8,8
209586	DIN 6204 2Z (2RS) d 20 D 47 B 14	801245	DIN 933 – M14X55 – 8,8	825836	DIN 935 – M42X3
210578	DIN 51210 d 50 D 78 B 22	801424	DIN 6208 d 40 D 80 B 18 P0	829470	DIN 933/DIN 931 – M14X100 – 8,8
210723	DIN 6304 d 20 D 52 B 15 P6	801446	DIN 6204 d 20 D 47 B 14 P0	841562	DIN 6210 d 50 D 90 B 20 P6
211941	BDS 2170 77 A 85	804605	DIN 935 – M10 – 8	842428	DIN 6210 d 50 D 90 B 20 P6
211973	DIN 125 10	804705	DIN 6215 N d 75 D 130 B 25 P6		
211974	DIN 125 12	804793	DIN 5300 78 62 A		
211978	DIN 125 30	804901	DIN 933 – M12X90 – 8,8		
211981	DIN 125 24	805062	DIN 933 – M6X16 – 8,8		
211986	DIN 94 – 2,5X14	805149	DIN 933 – M8X18 – 8,8		
211989	DIN 94 – 8X80 – 4,8	805214	DIN 933 – M10X20 – 8,8		
219202	DIN 934 – M14 – 8	805215	DIN 933 – M6X40 – 8,8		
219318	DIN 85 – A M8X40	805232	DIN 933 – M8X16 – 8,8		
221394	BDS 2170 77 A 100	805258	DIN 933 – M10X25 – 8,8		

Old Designation

52	MT	312	H10	V1	4/1	M E K	20/6	
Electrical equipment code	Hoist type	Hoist size	Hook travel (m)	Lifting speed (m/min)	Reeving	Modification	Trolley speed (m/min)	
20	Emergency stop and thermal protection	MT	305	H7	V1	2/1	M Micro lifting speed	12
21	Emergency stop, thermal protection and latch key	MTL	308	H10	V2	4/1	E Electrical trolley	15
42	Load limiter		312	H13			N Normal headroom	20
44	Load limiter and thermal protection		316	H14			K Monorayl trolley – Low headroom	20/5
52	Load limiter, emergency stop and latch key		525	H20				20/6
53	Load limiter, emergency stop, thermal protection and latch key			H26				12/4
								15/5

New Designation

1	MT	305	H10	V8	2/1	M	N	53	20/6
Load capacity (t)	Hoist type	Hoist size	Hook travel (m)	Lifting speed (m/min)	Reeving	Type of lifting speeds	Suspension type	Electrical equipment code	Trolley speed (m/min)
1	MT	305	H7	V4	2/1	M Micro (double speed)	N Normal headroom	20 Emergency stop and thermal protection	12
2	MTL	308	H10	V8	4/1	S Single speed	F Foot mounted	21 Emergency stop, thermal protection and latch key	15
1.6		312	H13			I Inverter control	LC Low headroom with counterweight	42 Load limiter	20
3.2		316	H14				LB Low headroom with balace wheel	44 Load limiter and thermal protection	20/5
2.5		525	H20					52 Load limiter, emergency stop and latch key	20/6
5			H26					53 Load limiter, emergency stop, thermal protection and latch key	12/4
10									15/5

Podem recommend when buying a hoist to buy following spare parts:

- Rope Guide
- Rectifiers for lifting and travel motors (if the hoist is with cylindrical motor)
- Brake set for lifting and travel motors (if the hoist is with cylindrical motor)
- Brake fan for lifting motor (if the hoist is with conical motor)
- Driving and Driven travel wheels (If the hoist is monorail)
- Pinion (if the hoist is monorail)
- Gear block (if the hoist is monorail)
- Wire rope (lengths for all hoists are in tables 2.2 and 2.5)

Group 14 – Accessories

Table 14			
Pos.	Name	Qty	Catalog №
1	Hooks for mounting the springs of the rope guide	2	520148
2	Tongs for rope guide mounting	1	520191
3	Wrench 46 mm*	1	520208
4	Wrench 65 mm*	1	520192
5	Wrench for fan mounting KG 1605, KG 1608, KG 2009, KG 2110	1	520210
6	Wrench for fan mounting KG 2008, KG 2011, KG 2012, KG 2612	1	520211
7	Wrench for fan mounting KG 2412, KG 2714-24/6	1	516048
8	Wrench for fan mounting KG 2714-4, KG 2714-6, KG 3317	1	520212
9	Wrench for fan mounting KG 3517**	1	520214
10	Software + Cable for dynamometric pin***	1	505735
11	Tester for dynamometric pin***	1	505734
12	Spray with blue paint	1	505542
13	Eye bolt	2	

– * It is for use in normal and low headroom hoists, for adjustment of traveling on beams with different than preset width

– ** Wrench for loosening/tightening of brake fan nut in conical motors.

– *** For setup of dynamometric pin.



Request for spare parts for electric hoist, type , serial number ,
year of production , operation mode group acc. to FEM ,
power supply: voltage ; frequency

№	Spare part	Qty	Catalog №
1			
2			
3			
4			
5			
6			
7			
8			
9			
10			
11			
12			

Spare parts to be delivered at the following address:

.....
.....
.....



Date:

Customer:



A series of horizontal dotted lines for writing, spaced evenly down the page.



A series of horizontal dotted lines for writing, spaced evenly down the page.



A series of horizontal dotted lines for writing, spaced evenly down the page.

Spare Parts Catalogue

Standard Electric Wire Rope Hoists

MT and MTL Series

May 2015

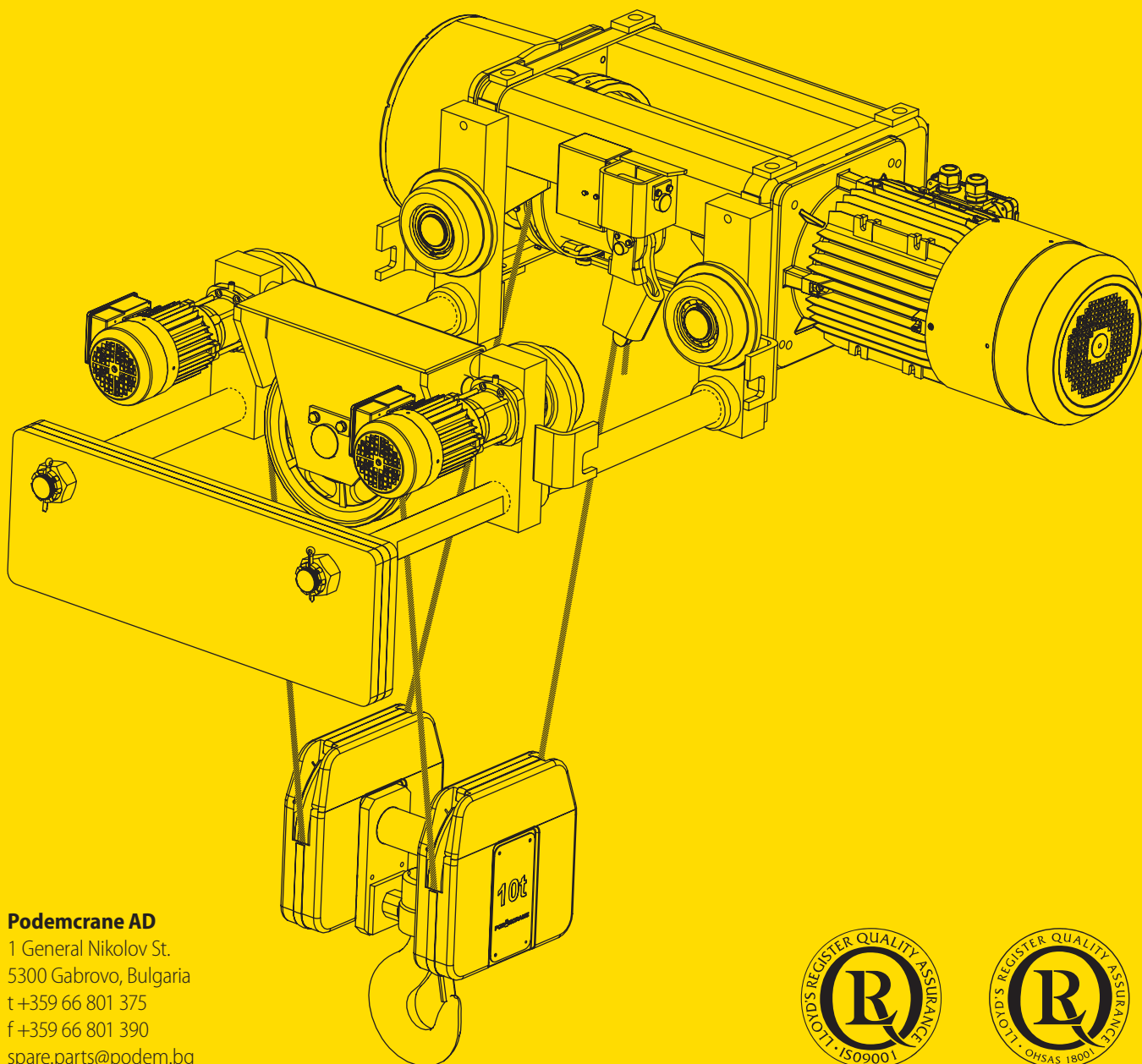

Podemcrane AD

1 General Nikolov St.
5300 Gabrovo, Bulgaria
t +359 66 801 375
f +359 66 801 390
spare.parts@podem.bg
podem.bg

